

Thermocouple Application

Section 3

Precision Analog Applications Seminar

Thermocouples

Outline

This session will focus on the thermocouple

- ◆ Theory
- ◆ Measurement and reference junctions
- ◆ Parasitic junction
- ◆ Cold junction compensation
 - Software
 - Hardware
- ◆ Thermocouple circuits
- ◆ Nonlinearity and compensation

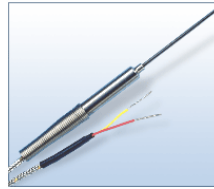
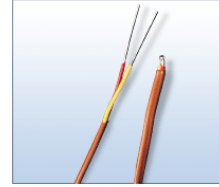

Source: Omega Engineering Inc.

Thermocouples are a popular temperature sensor choice due to their wide temperature range capability and rugged design. This session will focus on basic thermocouple theory, principles and how one goes about applying them in a manner such that they produce their best performance.

Precision Analog Applications Seminar

Thermocouples

A common and important use of thermocouples by engineers!



Precision Analog Applications Seminar

Thermocouples

Theory – the fundamentals

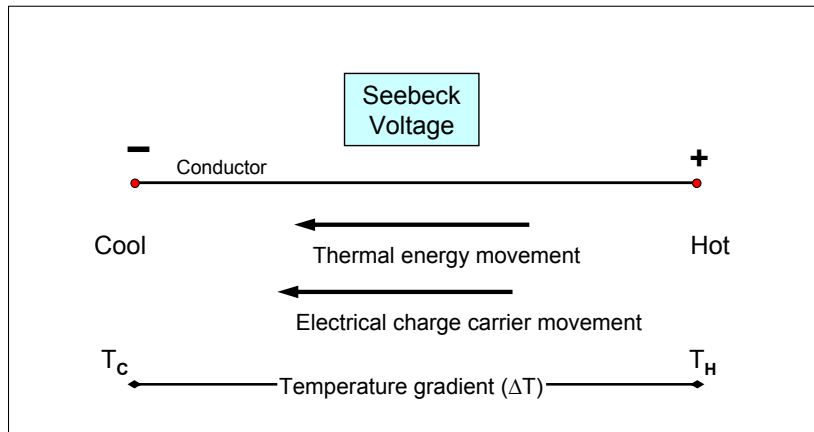

A simple wire of any metal will produce a voltage when there is a temperature difference between the two ends. Yes... believe it.

www.dataforth.com/catalog/pdf/an106.pdf

When one end of a conductive material is heated to a temperature larger than the opposite end, the electrons at the hot end are more thermally energized than the electrons at the cooler end. These more energetic electrons begin to diffuse toward the cooler end. Of course, charge neutrality is maintained; however, this redistribution of electrons creates a negative charge at the cool end and an equal positive charge (absence of electrons) at the hot end. Consequently, heating one end of a conductor creates an electrostatic voltage due to the redistribution of thermally energized electrons throughout the entire material. This is referred to as the "Seebeck effect." While a single wire does not form a thermocouple, this "Seebeck effect" is the fundamental property that governs thermocouple operation.

Precision Analog Applications Seminar

Thermocouples

Theory – the fundamentals

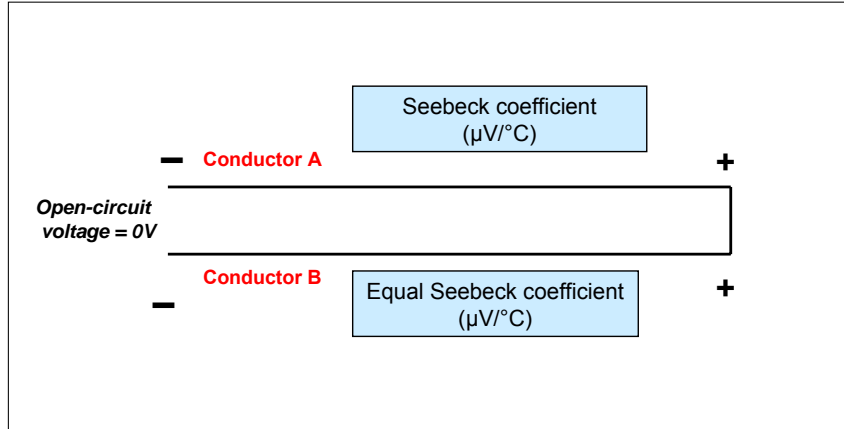

Direct measurement of the Seebeck voltage of a single wire is impossible. Another wire of the same metal produces an identical Seebeck voltage resulting in a net voltage of 0V at the measurement points.

Precision Analog Applications Seminar

Thermocouples

Theory – the fundamentals

Thermoelectric Sensitivity

The Seebeck coefficients (thermoelectric sensitivities) of some common materials at 0 °C (32 °F) are listed in the following table.

Material	Seebeck Coeff. *	Material	Seebeck Coeff. *	Material	Seebeck Coeff. *
Aluminum	3.5	Gold	6.5	Rhodium	6.0
Antimony	47	Iron	19	Selenium	900
Bismuth	-72	Lead	4.0	Silicon	440
Cadmium	7.5	Mercury	0.60	Silver	6.5
Carbon	3.0	Nichrome	25	Sodium	-2.0
Constantan	-35	Nickel	-15	Tantalum	4.5
Copper	6.5	Platinum	0	Tellurium	500
Germanium	300	Potassium	-9.0	Tungsten	7.5

*: Units are $\mu\text{V}/^\circ\text{C}$; all data provided at a temperature of 0 °C (32 °F)

Source: www.efunda.com/

Different metals, metal alloys and semiconductor materials are employed in the construction of thermocouples. Their thermoelectric sensitivities, or Seebeck coefficients, can vary significantly in magnitude and may be positive or negative.

The materials listed have been well characterized, standardized, and form the basis for the commonly available thermocouples.

Note that different tables may list a somewhat different Seebeck coefficient for a given material. Be sure to note the temperature at which the coefficient is specified. Thermocouples are not perfectly linear across temperature. They may produce a different Seebeck voltage coefficient within the different temperature ranges that they operate. This occurs because the Seebeck voltage generated is dependent on a complex mix consisting of the Seebeck, Peltier and Thomson effects.

Precision Analog Applications Seminar

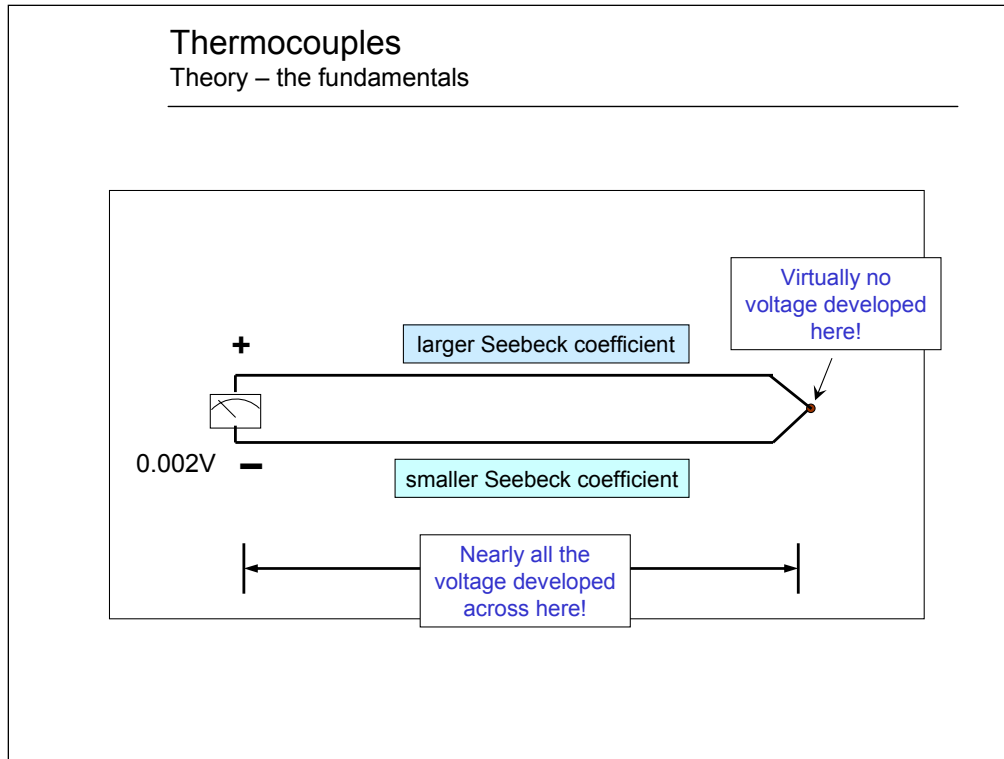

Perhaps the most misunderstood issue regarding thermocouples is that no voltage is produced at the measurement junction. The junction completes the circuit so that current flow can take place. A voltage is developed along each wire as the temperature changes. The voltage difference is observed at the receiving end because the two differing metals have different Seebeck coefficients and produce a voltage difference at the meter point.

Misinformation about thermocouples abounds on the internet with statements such as "... the junction between two metals generates a voltage which is a function of temperature." Many other references and web sites make the same error. A more accurate explanation can be found at:

www.dataforth.com/catalog/pdf/an106.pdf

Precision Analog Applications Seminar

Thermocouples Theory – the fundamentals

The thermocouple junction

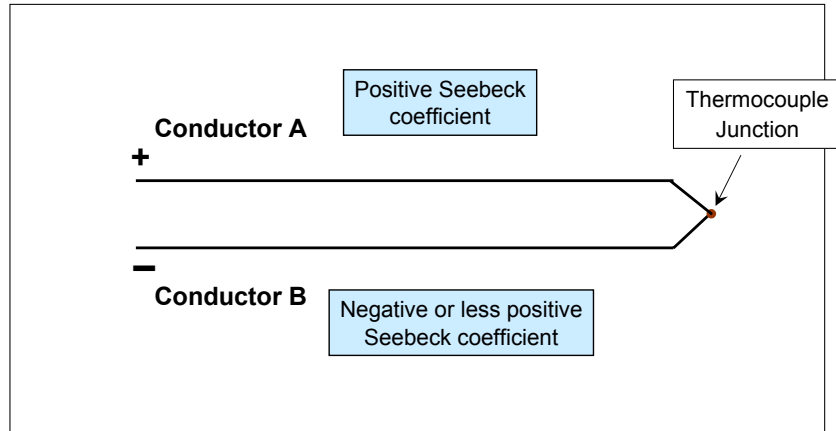

A thermocouple junction is formed when two dissimilar metals, metal alloys or semiconductor materials are joined together. However, the practical thermocouple not only consists of the junction, but connecting leads made of the same dissimilar metals. In use, the thermocouple junction is exposed to the “hot” (or cold) temperature point. The leads connect between the junction and a measurement device located at a different temperature such as room. It is along these lead lengths where the temperature gradient is present resulting in the generation of the two individual Seebeck EMF’s.

Precision Analog Applications Seminar

Thermocouples Theory – the fundamentals

Thermocouples types and their response

KEY TO SYMBOLS

E	Chromel - Constantan
J	Iron - Constantan
K	Chromel - Alumel
T	Copper - Constantan
B	Platinum 6% Rhodium vs. Platinum 30% Rhodium
R	Platinum vs. Platinum 13% Rhodium
S	Platinum vs. Platinum 6% Rhodium
W/W26/Re	Tungsten vs. Tungsten 26% Rhenium
W5Re/W26Re	Tungsten 5% Rhenium vs. Tungsten 26% Rhenium
W3Re/W25Re	Tungsten 3% Rhenium vs. Tungsten 25% Rhenium

Data sources: NBS Monograph 125 and
Hokins Manufacturing Company

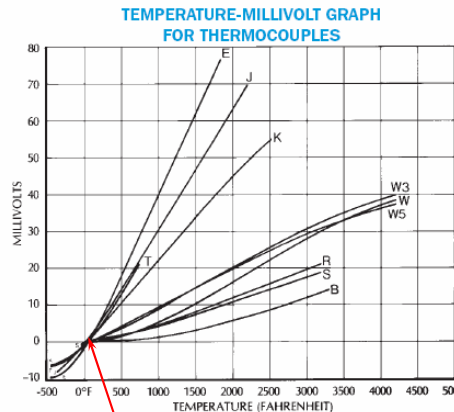

All curves relative to 0°C reference

Thermocouples are classified by type which is associated with their useable temperature range, sensitivity and accuracy. The commonly used metals include: chromium, copper, nickel, iron, platinum, rhodium, and rhenium.

This chart provides the thermal response of several different types of thermocouples. Notice that the copper-constantan “type T” thermocouple has a limited use temperature range compared to the others.

Also note the differences in the thermocouple sensitivities and their linearity $\Delta V/\Delta T$. Those having a more limited temperature range tend to have better linearity characteristics. Because of poor linearity some higher temperature thermocouples aren't intended for measuring temperatures below 0°F (-18°C).

As previously mentioned the Seebeck coefficient may be listed with a different value, which may depend on the source of the information. The specified temperature was mentioned as a cause for the difference. For example, the copper-constantan “type-T” thermocouple is listed with a Seebeck coefficient of $41\mu V/^\circ C$ at $25^\circ C^*$, and $38.75\mu V/^\circ C$ at $0^\circ C$, in the Agilent Technologies, Application note 290. A value of $38\mu V/^\circ C$ is often listed.

NOTE: A similar value is given at the “efunda” website which lists a “type-T” Seebeck coefficient of $40.6\mu V/^\circ C$ at $25^\circ C$.

Precision Analog Applications Seminar

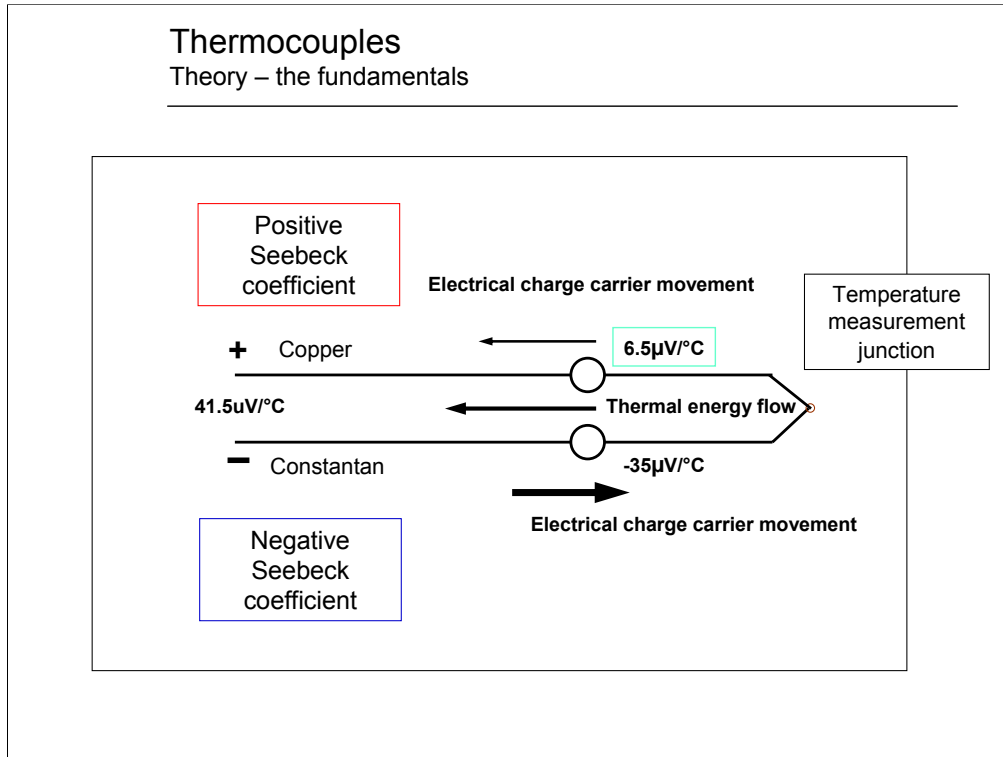

Different thermocouple materials have different capacities for moving charge carriers in response to thermal flow. The current level in one conductor will overcome or complement the potential for thermally generated current flow in the other conductor. The result is a continuous current flow that is the difference between the currents generated in the two conductors.

For this example, the two selected metals are copper and constantan which have Seebeck coefficients of approximately $+6.5\mu\text{V}/^\circ\text{C}$ and $-35\mu\text{V}/^\circ\text{C}$, respectively. The difference between these two coefficients results in a thermocouple sensitivity of about $+41.5\mu\text{V}/^\circ\text{C}$ at 0°C .

Precision Analog Applications Seminar

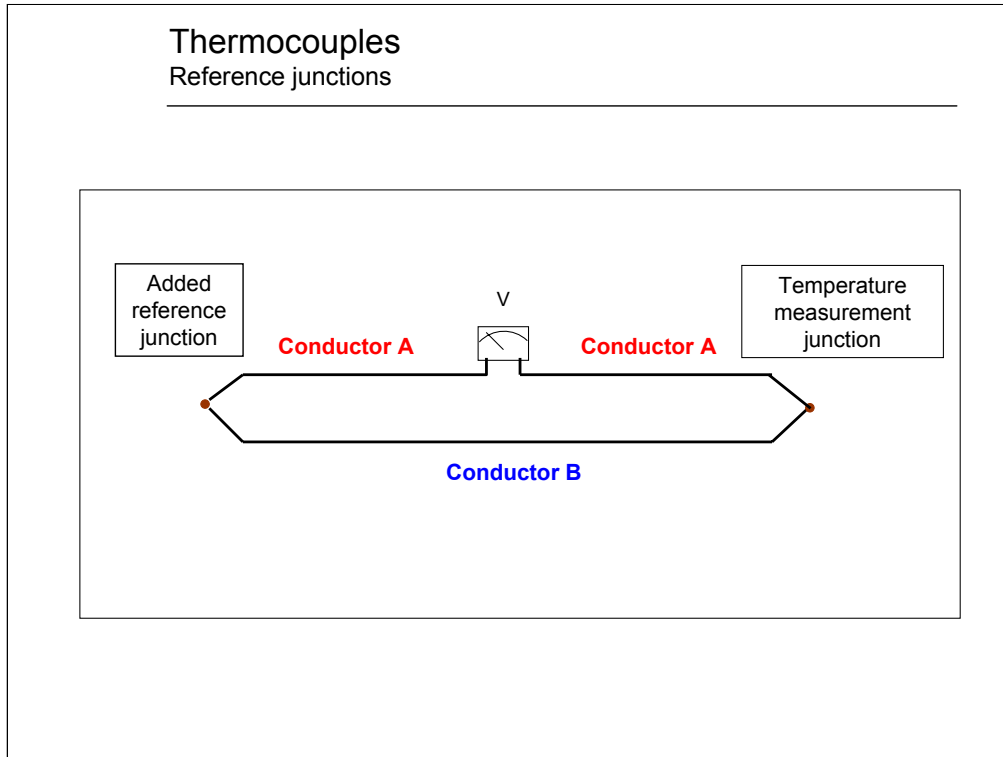

The thermocouple example in the previous slide had a thermoelectric sensitivity of about $41.5\mu\text{V}/^\circ\text{C}$. That is an important bit of information, but equally important and missing is a temperature reference point. A temperature change can be measured, but the actual temperature is still an unknown. Adding a second junction and holding it at a known reference temperature allows an unknown temperature at the other junction to be found.

Since the circuit is a continuous loop in which current flows it can be opened and a meter inserted. The voltmeter has a high internal resistance and produces a voltage proportional to the current. Keep in mind that the voltage is strictly dependent upon temperature; the relationship between Seebeck voltage and temperature is fixed. However, the relationship between temperature and current is variable and will depend on the overall circuit resistance.

Precision Analog Applications Seminar

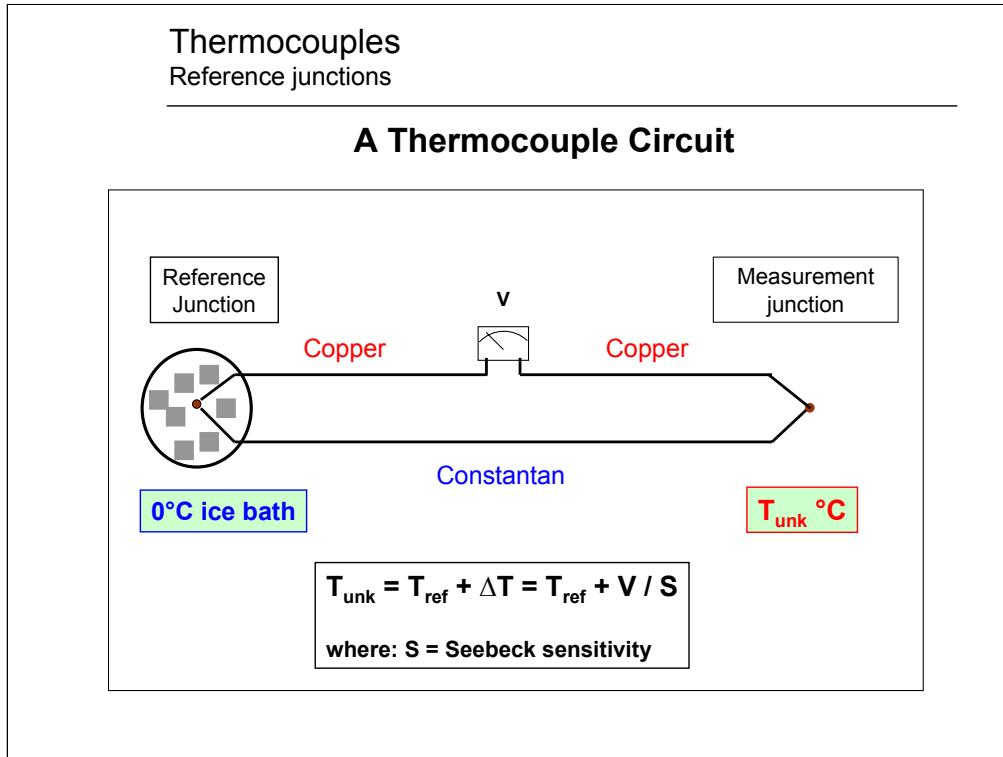

Placing the reference junction in an ice bath with a temperature very close to 0°C allows for the unknown temperature to be determined using the following relations:

$$V = S \cdot \Delta T$$

$$\Delta T = V / S$$

where: V = measured voltage, S = Seebeck coefficient (V/°C)

Then:

$$T_{\text{unk}} = T_{\text{ref}} + \Delta T = T_{\text{ref}} + V / S$$

Precision Analog Applications Seminar

Thermocouples Reference junctions

An example

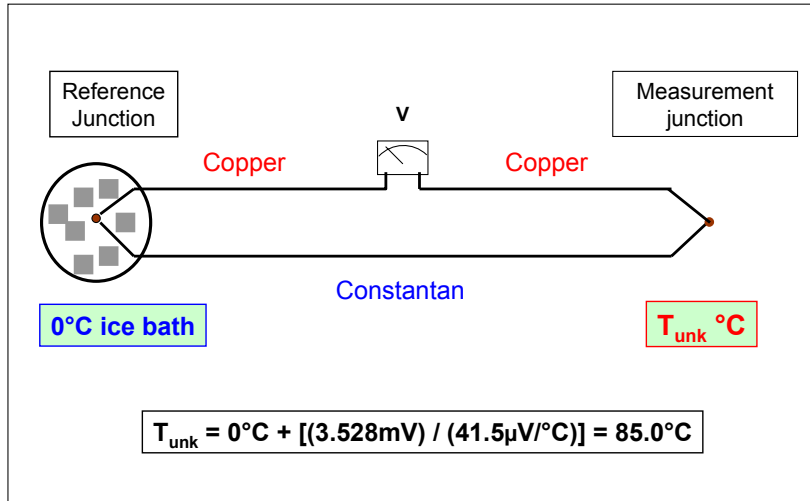

For example:

If a copper-constantan thermocouple produces a voltage of 3.528mV

then, $T_{\text{unk}} = 0^{\circ}\text{C} + [(3.528\text{mV}) / (41.5\mu\text{V}/^{\circ}\text{C})] = 85.0^{\circ}\text{C}$

Precision Analog Applications Seminar

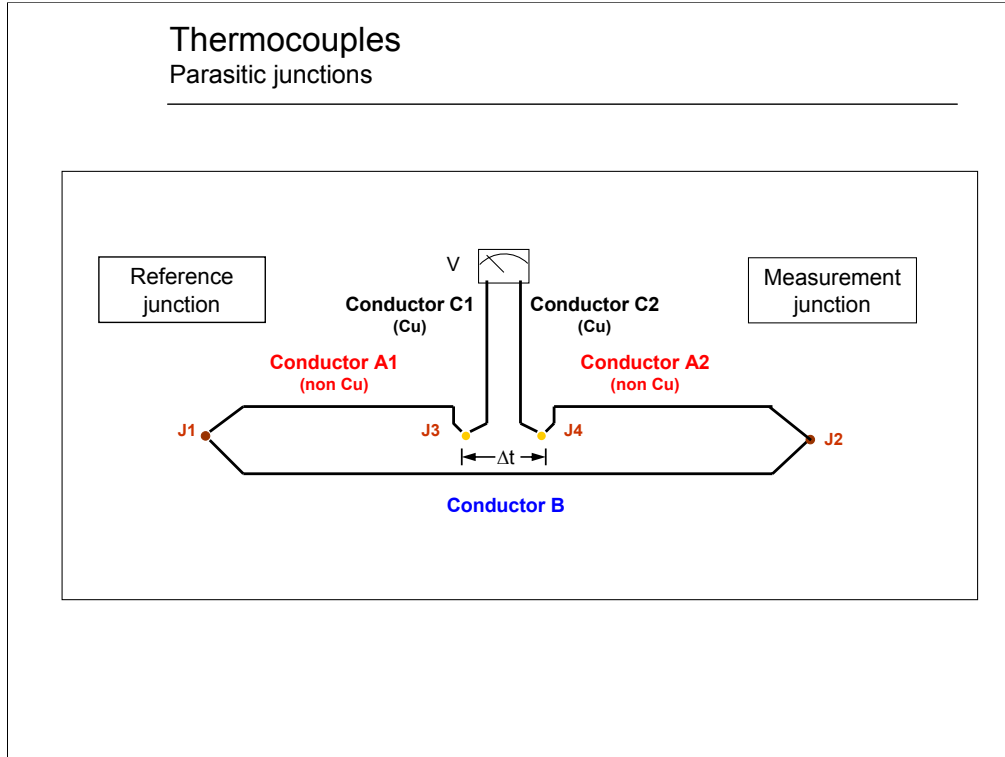

A copper-to-copper connection is unique to the case of the “type T” thermocouple. But when a thermocouple other than the “type T” is employed parasitic thermocouples are created at the meter connections or leads leading to the meter function. These parasitic thermocouples may introduce measurement errors. Each generates a Seebeck voltage dependent on the junction materials and relevant temperature gradient.

Precision Analog Applications Seminar

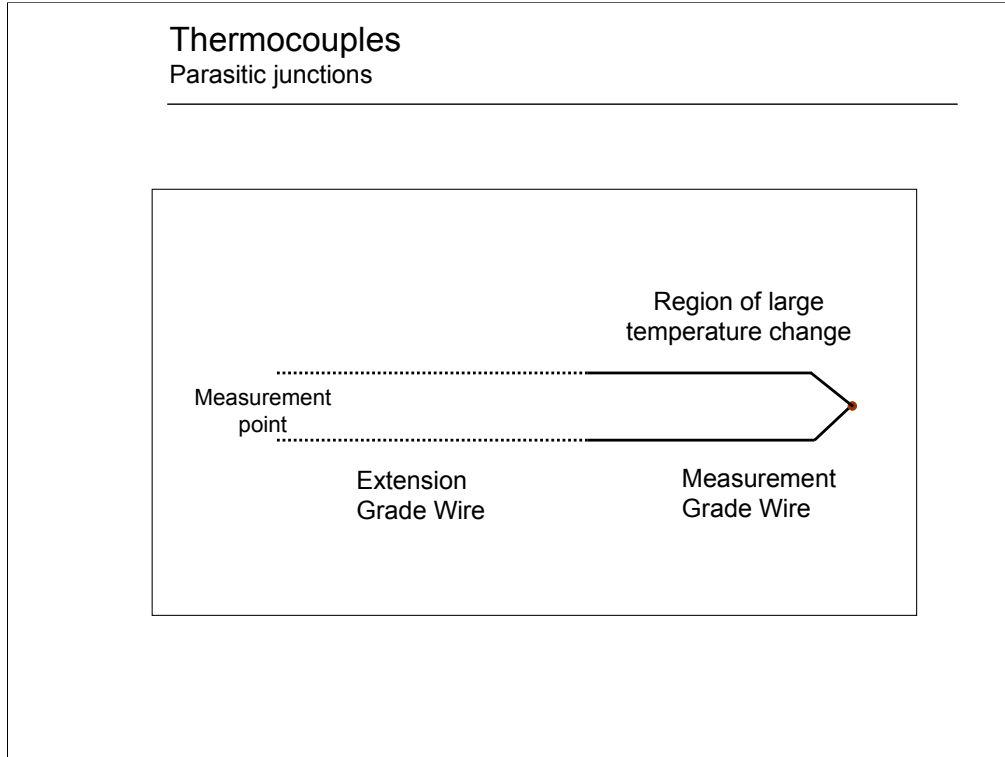

One way to avoid the problems associated with creating parasitic thermocouple junctions is to use extension wires similar in characteristics to the actual thermocouple section.

Thermocouple wire can be relatively expensive and comes in various accuracy grades. Measurement-grade wire is made of higher purity metals and more accurately controlled alloys, thus providing greater accuracy. This higher quality wire is often used only in the region of greatest temperature change where virtually all the voltage is produced. Depending on the application, this may be only in the first few centimeters near the measurement junction. Lower quality wire called "extension grade" can be used to connect to the measurement system without seriously degrading accuracy.

Precision Analog Applications Seminar

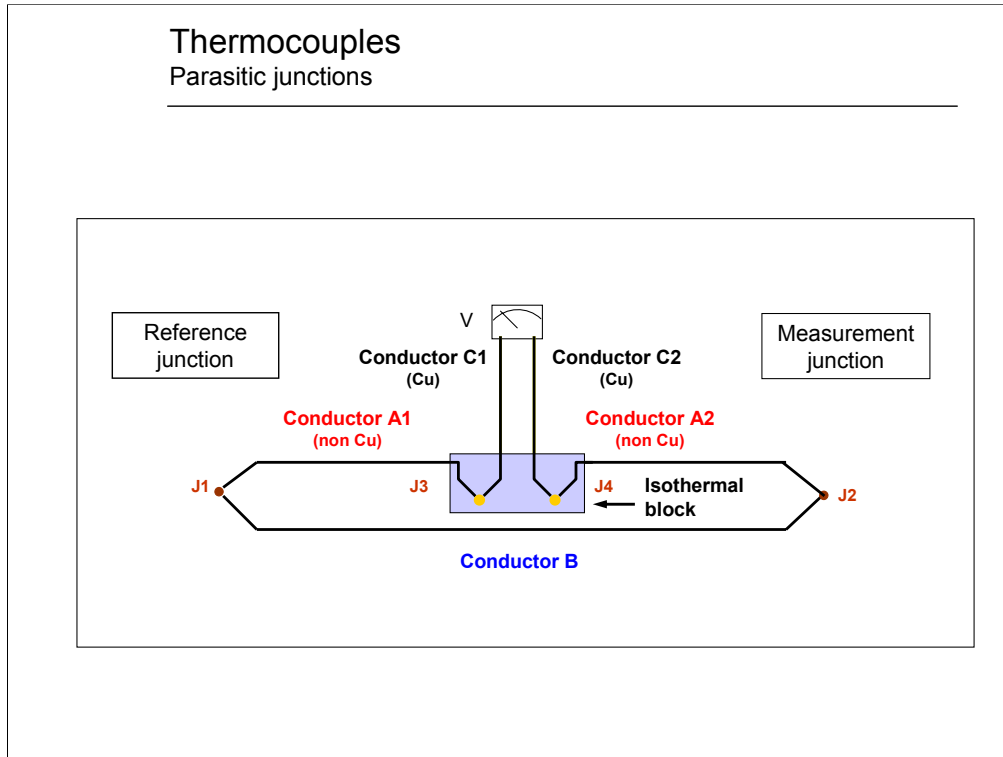

With the “type T” thermocouple the copper line can be opened and directly connected to copper extension lines without forming parasitic thermocouples. But with other materials that won’t be the case. Even then it’s not the end of the world because the two parasitic junctions, J3 and J4, will produce equal and opposite voltages - provided they are identical and at the same temperature. Moderately accurate measurements will be obtained even if they aren’t.

A way to help assure this is to make the extension wire connections at an isothermal block. The block maintains the two junctions at the same temperature and provides nearly identical electrical connection characteristics. The block must be insulated for the electrical connections and provide for good thermal conductivity between them.

Precision Analog Applications Seminar

Thermocouples
Parasitic junctions

Isothermal block example

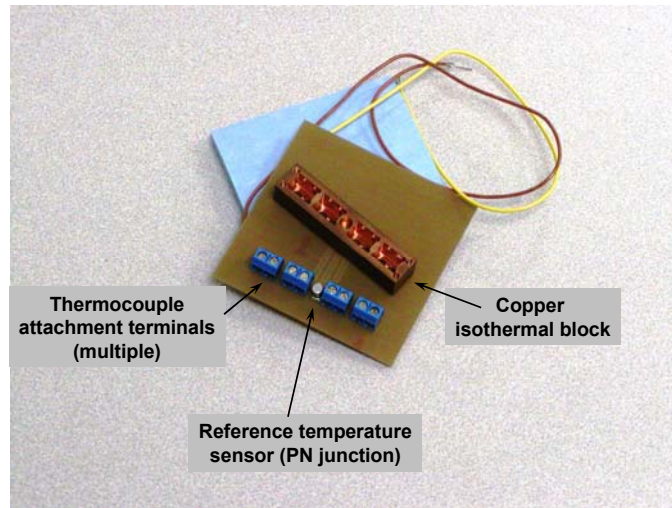

This is an image of an isothermal block that is intended for 4 individual thermocouples. The copper isothermal block fits over plastic terminal blocks. It has sufficient thermal mass such that all of the terminals should be held very close in temperature.

It also has holes along the front edge for the thermocouple wires to pass through and holes on the top to access the terminal block screws.

Precision Analog Applications Seminar

Thermocouples

Cold junction compensation

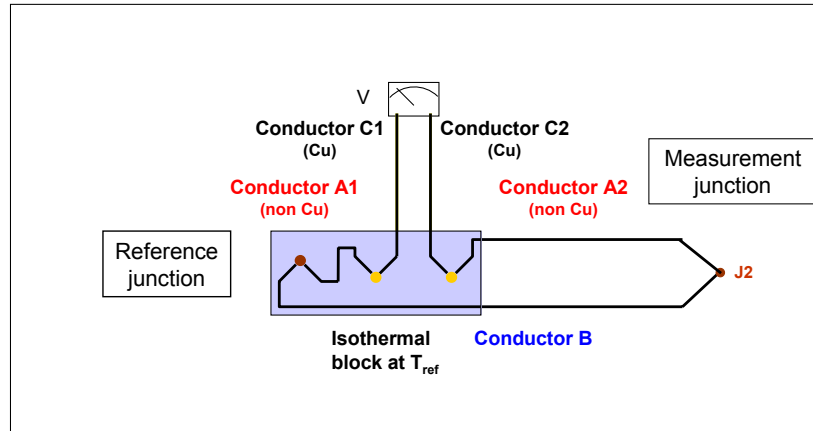

Often it is not practical to include an ice bath reference as part of the measurement system. Shown here the reference junction has now been located at the isothermal block along with the parasitic junctions. As long as the parasitic junctions are held at a common temperature they will cancel each other's Seebeck voltage contribution.

The reference junction will still require establishment of a reference temperature, but this can be accomplished by software or hardware compensation techniques.

Precision Analog Applications Seminar

Thermocouples

Cold junction compensation

Cold junction compensation Software implementation basis

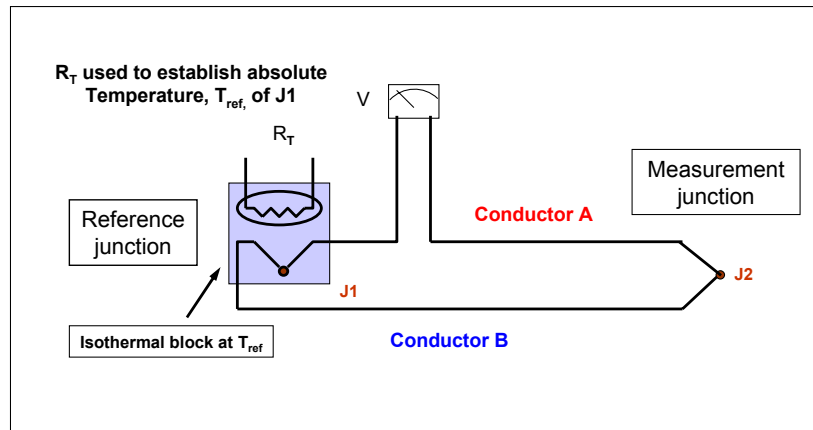

A secondary temperature sensing transducer such as a thermistor, RTD or semiconductor junction may be attached at the isothermal block to indicate the block's temperature. R_T has a resistance that is proportional to the isothermal blocks temperature. The temperature response characteristics of this secondary transducer must be an established known in order to be utilized. The resistance is then converted to another electrical property such as voltage, and then to its digital equivalent. This compensation voltage can then be summed with the measured voltage in the software. This technique is known as software compensation.

One may question why one wouldn't use this reference transducer to measure the temperature in the first place? The answer is that transducers of this type have a limited useful temperature range when compared to a thermocouple. And they also lack the physical properties required for many high temperature and/or physically demanding applications. Thermocouples are rugged, high temperature transducers that are often subjected to harsh environments with conditions that far exceed what the other transducers can withstand.

Precision Analog Applications Seminar

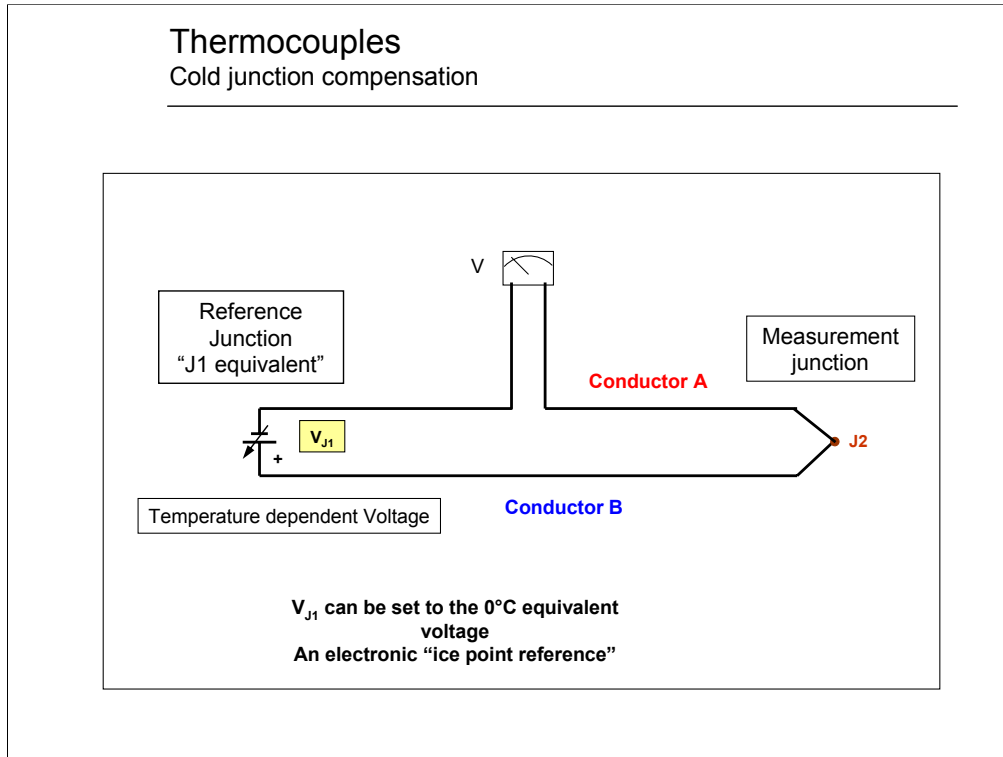

When subjected to an ice bath the reference junction develops a voltage specific to 0°C. An equivalent voltage source can be substituted in place of the junction to serve as a 0°C voltage reference. This electronic substitution for the ice bath is referred to as an "electronic ice point reference." This standard voltage is dependent on the particular thermocouple type and the values are established by the NIST. Electronic ice point references are available for many different types of thermocouples.

Precision Analog Applications Seminar

Thermocouples

Cold junction compensation

Cold junction compensation

Hardware implementation basis

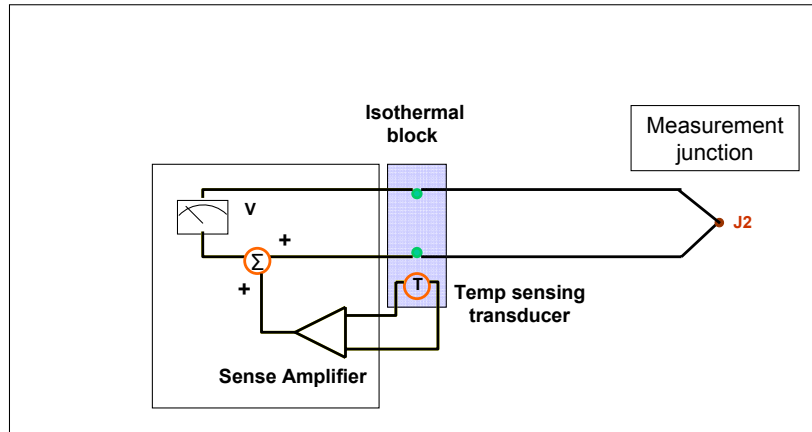

In a practical hardware compensation scheme the secondary transducer's voltage is appropriately gained and summed within the measurement circuit's path. The secondary temperature sensing transducer is mounted to the isothermal block. This can be a thermistor, RTD etc. Its resistance tracks the temperature of the isothermal block and is converted by the sense amplifier to a voltage that is summed or subtracted at the summing junction.

The secondary sense transducer response over temperature has to be taken into account so that the correct voltage is summed into the measurement path.

Precision Analog Applications Seminar

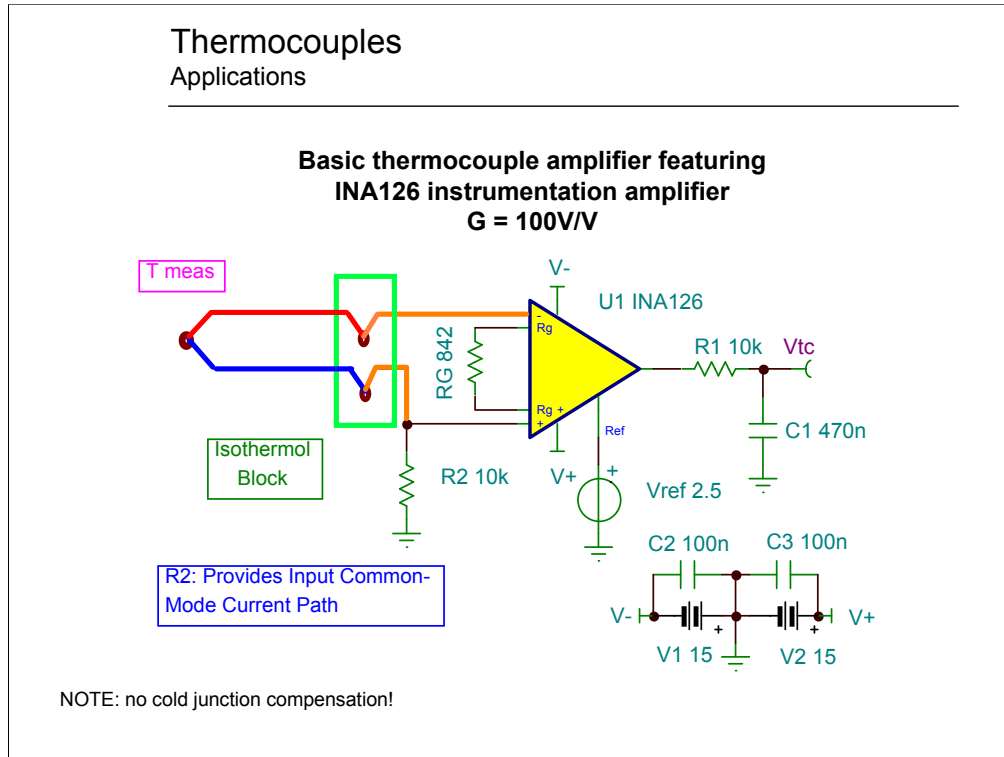

Since thermocouples produce DC signal levels in the tens or hundreds of microvolts it is necessary to provide additional gain for further signal processing. Interfacing the thermocouple is a simple matter of using a 3-amplifier, instrumentation amplifier. In this case an INA126 MicroPOWER instrumentation amplifier is employed and provides a voltage gain of 100V/V. Despite its very low power usage ($I_q = 200\mu\text{A}$ max) its speed is completely adequate for this type of application. Note that this simple circuit does not include a reference, or equivalent, and only temperature change would be observed. The other complexities can be added to suit the application.

It should be noted that with amplifiers like the INA126 that have extremely high input impedance ($\approx 10^9$) that a path must be provided for the input bias currents. With floating transducers, like the thermocouple, this is easily accomplished by adding a resistor off one side to ground (R_2).

One might be tempted to think that this circuit is not useable in its present state; however, it may be suitable for low accuracy applications. The main drawback is the lack of cold junction compensation, but may only introduce a small error if the temperatures being measured are high. For example, with measurement temperatures in excess of 1000°C , the error caused by not including the cold junction temperature would likely be tolerable.

Precision Analog Applications Seminar

Thermocouples Applications

Single supply OPA335 thermocouple amplifier features moderate temperature accuracy

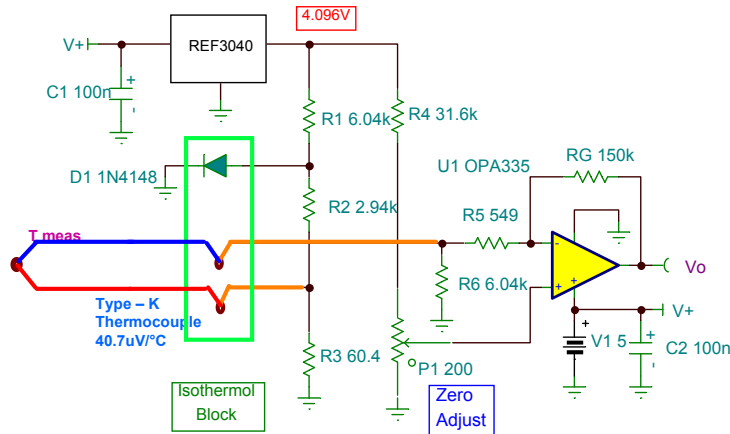

This is a complete thermocouple amplifier for a type K thermocouple. It features an OPA335 CMOS, zero-drift op-amp and includes cold junction compensation (isothermal block) and incorporates a diode thermal sensing circuit for hardware compensation.

This circuit will produce moderately accurate results limited somewhat by the inexact diode characteristics. Although a PN junction is the most linear of all temperature sensors, its accuracy at a given temperature can vary due to the diode's saturation current characteristics. A 10:1 difference in the diode saturation current results in a 60mV difference in forward junction voltage. From one batch of diodes to the next, the forward voltage can be quite different which would result in a different cold junction temperature.

Precision Analog Applications Seminar

Thermocouples Applications

INA128 Precision thermocouple amplifier with cold junction compensation ($G = 100V/V$)

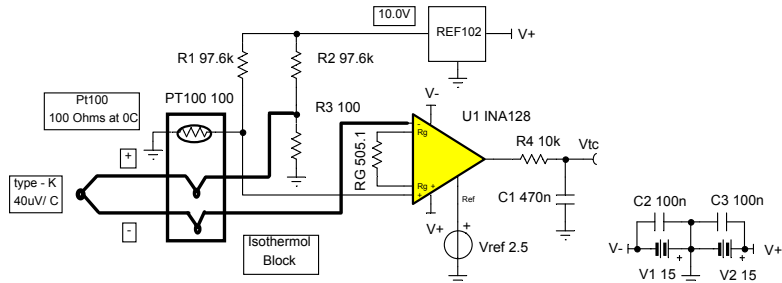

ISA Type	Material	Seebeck Coeff $\mu V/^{\circ}C$	R1, R2
E	+ Chromel - Constantan	58.5	66.5k Ω
J	+ Iron - Constantan	50.2	76.8k Ω
K	+ Chromel - Alumel	39.4	97.6k Ω
T	+ Copper - Constantan	38.0	102k Ω

This thermocouple amplifier uses the INA128 precision instrumentation amplifier in a gain of 100V/V. Cold junction compensation is accomplished with a Pt100 RTD. It exhibits very good linearity over most of its operating range and the accuracy can be specified with a fraction of a degree. Therefore, from one RTD batch to the next, the temperature accuracy performance can be duplicated.

The table lists the resistor values for R1 and R2 associated with various thermocouples. These resistors establish RTD bias such that the associated voltage corresponds to the block temperature.

Precision Analog Applications Seminar

Thermocouples Nonlinearity and compensation

Thermocouple Linearity (or Nonlinearity!)

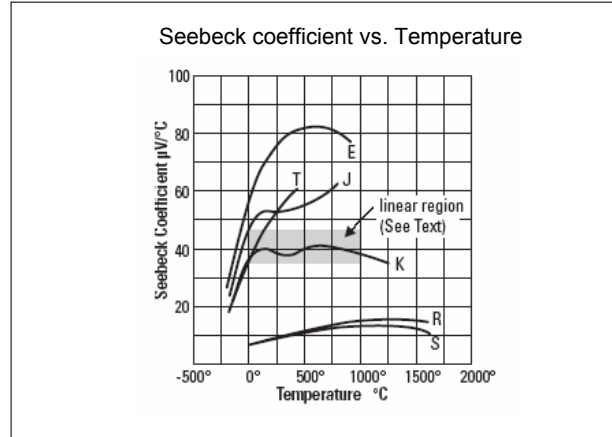

Source: Agilent Technologies, Application note 290

Up to this point we have been using a fixed constant for the Seebeck coefficient, but mention has been made that it will vary within the thermocouple's useable temperature range. For some types of thermocouples the coefficient may be 2 to 3 times higher within portions of the operating temperature range. This lack of linearity, or nonlinearity, will result in large temperature measurement errors if some form of linearization is not applied.

There are a number of ways one may go about correcting for the thermocouple's nonlinearity, but all rely on applying linearization coefficients to the measured voltage. The coefficients are often mathematically derived or acquired from look-up tables. Categorization and fast algorithms can be used to speed up the process. The choice really depends on the power of the data acquisition system employed in the measurement system.

Precision Analog Applications Seminar

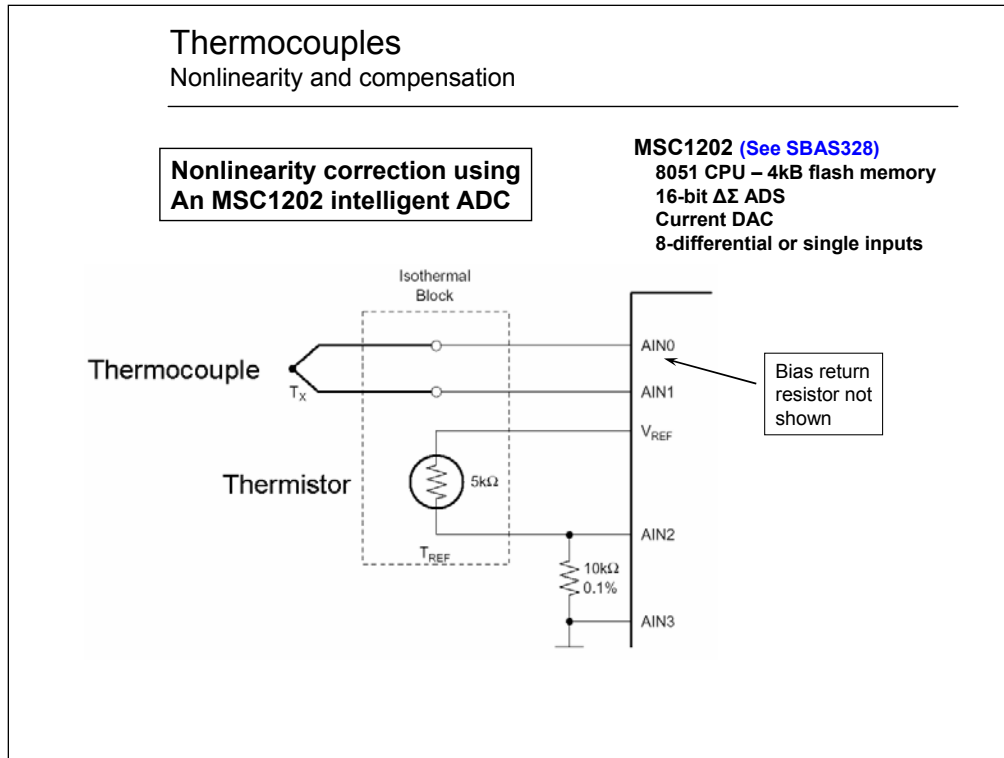

This circuit does not use a linearization circuit for the thermistor, it simply uses a general-purpose equation to convert the resistance into a temperature. That temperature is then used to calculate the voltage for the thermocouple type which is used at that same temperature. This procedure calculates the voltage from 0°C to T_{REF} . The voltage is then added to the voltage measured from the thermocouple. The total voltage is then used to calculate the temperature at the end of the thermocouple.

See TI applications report SBAA134 for an extensive treatment of thermocouple temperature measurements with $\Delta\Sigma$ ADCs.

Precision Analog Applications Seminar

Thermocouples Nonlinearity and compensation

Polynomial Correction

The polynomial equation has the form:

$$T = a_0 + a_1x + a_2x^2 + a_3x^3 \dots + a_nx^n$$

where: **T** = temperature
x = thermocouple EMF in volts
a = polynomial coefficients associated with the order
n = maximum polynomial order

For example:

Poly order	Type T, Copper - Constantan -160 to 400C, +/-0.5C	Type K, NiCr - NiAl 0 to 1370C, +/-0.7C
	"a"	"a"
0	0.10086091	0.226584602
1	25727.94369	24152.109
2	-767345.8295	67233.4248
3	78025595.81	2210340.682
4	-9247486589	-860963914.9
5	6.97688E+11	48350600000
6	-2.66192E+13	-1.18452E+12
7	3.94078E+14	-1.3869E+13
8		-6.33708E+13

Common thermocouples have been well characterized by the NIST and the applicable polynomial coefficients are available in the NIST's Thermocouple Tables (page Z-203). The polynomial order is established for a maximum error of $\pm 1^\circ\text{C}$. The required order to achieve this will depend on the thermocouple type. If the application has a limited temperature range then a lower order polynomial correction will be sufficient.

The mathematical expression shows how the polynomials are applied to the measured EMF (voltage). The tables lists as an example the coefficients for both a type-T and type-K thermocouple.

Precision Analog Applications Seminar

Thermocouples

Summary

In Conclusion, the thermocouple:

- ◆ Produces a difference voltage in response to a temperature gradient developed along its length
- ◆ Must be referenced to a known temperature reference, a “cold junction,” for accurate temperature measurement
- ◆ Can be interfaced with bridge amplifier circuits that provide built-in, “cold junction” compensation
- ◆ Requires linearization for best over-temperature linearity response