

# The GlueX Detector

Workshop on Photon-Hadron Physics  
with the GlueX Detector

March 6, 2008

Matt Shepherd  
Indiana University

# Outline

- Design Inspiration:  
Hybrid Spectroscopy
- Detector Overview
  - Tracking
  - Calorimetry
  - PID/Potential  
Upgrades
  - Trigger/Electronics

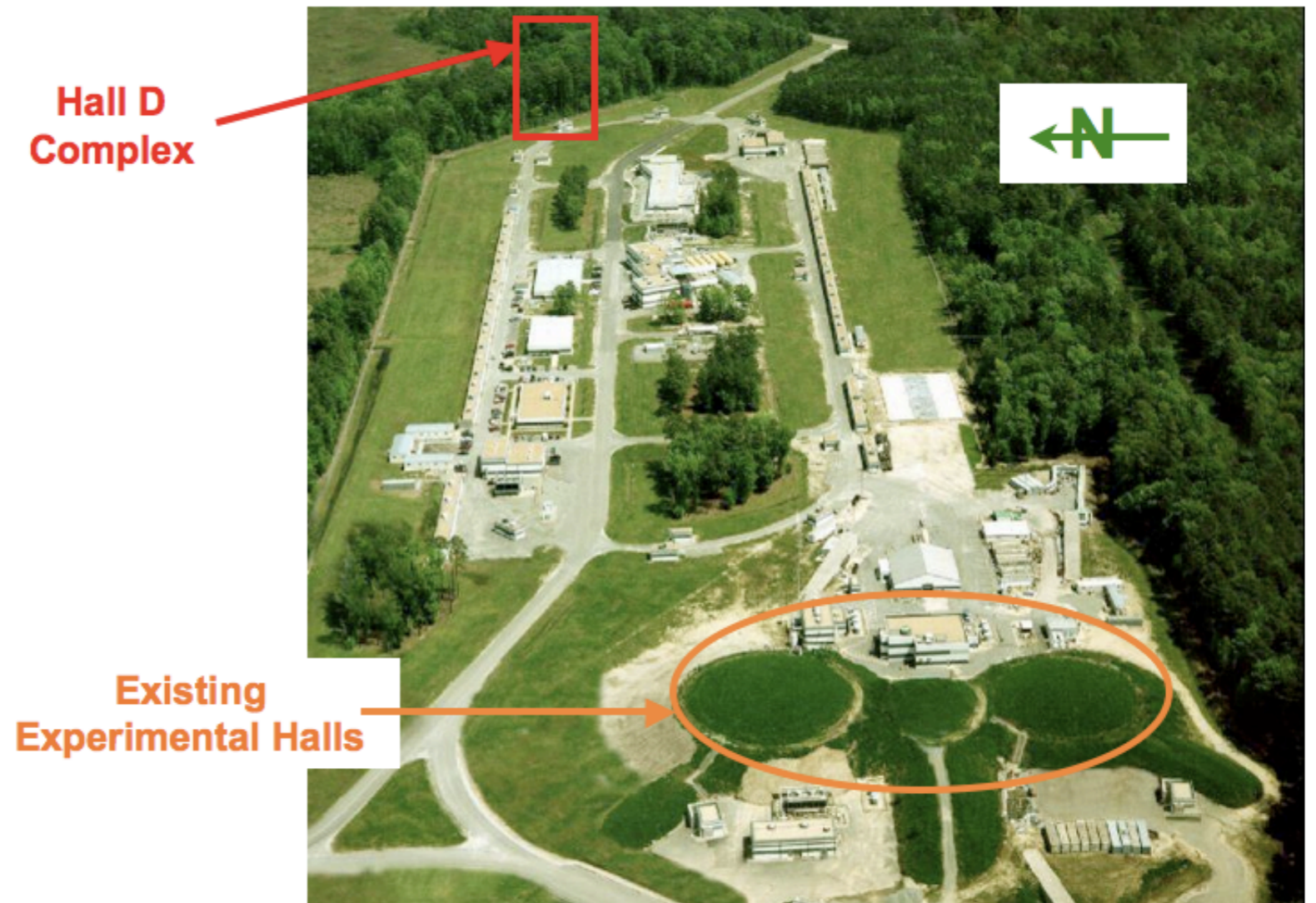

# Exotic Mesons

## Conventional Mesons

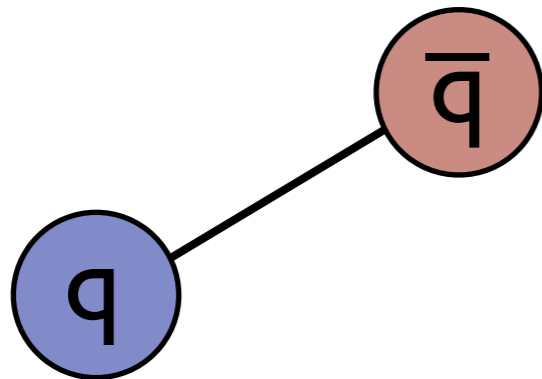

$$J = L + S$$

$$P = (-1)^{L+1}$$

$$C = (-1)^{L+S}$$

$$J^{PC} = 0^{-+}, 0^{++}, 1^{++}, 1^{--}, 1^{+-}, 2^{-+}, 2^{++}, \dots$$

## Hybrid Mesons

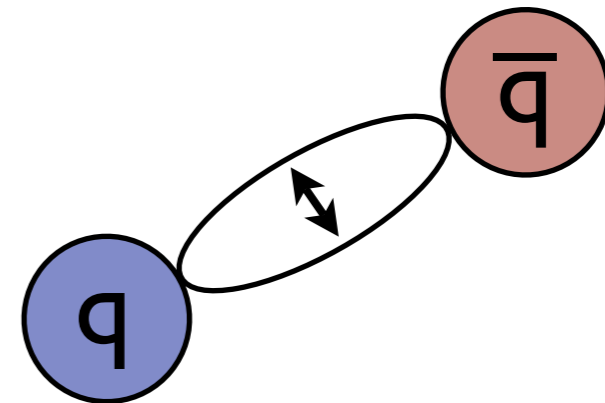

With flux tube contributing  
1 unit of angular momentum,  
exotic  $J^{PC}$  can be formed

$$J^{PC} = 0^{-+}, 0^{+-}, 0^{++}, 1^{++},$$

$$1^{--}, 1^{-+}, 1^{+-}, 2^{-+}, 2^{+-}, 2^{++}, \dots$$

Some have exotic  
quantum numbers

# Exotic Photoproduction

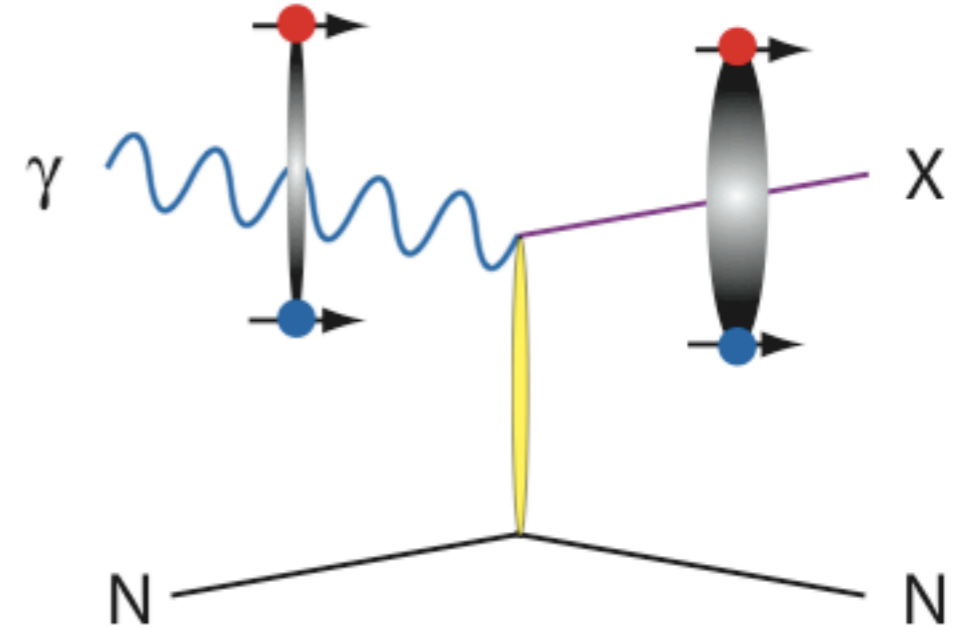
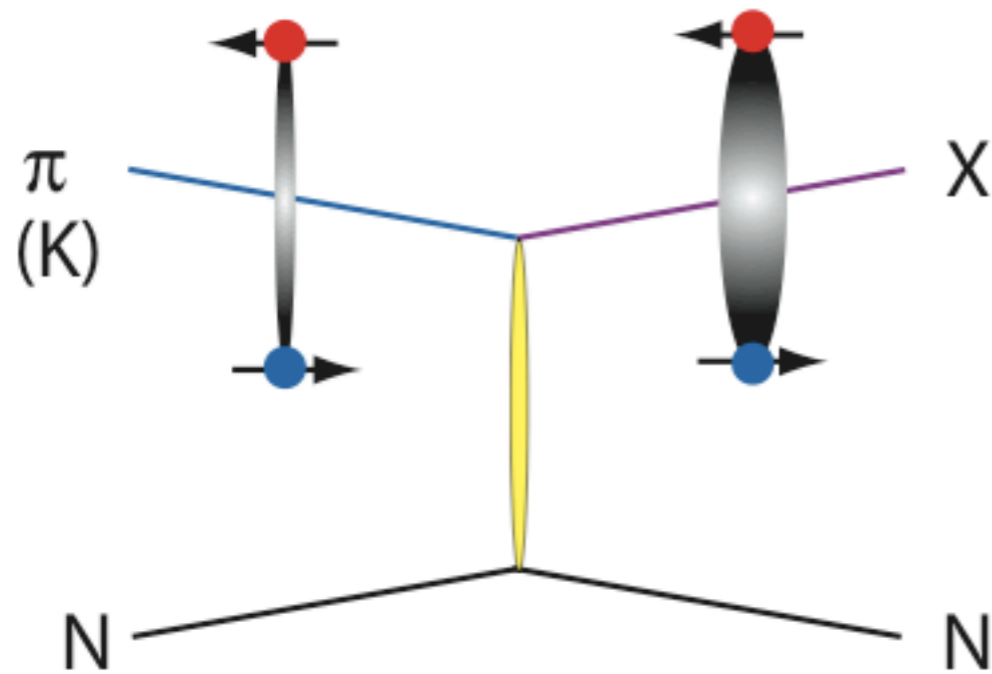

First excitation of flux tube expected to have  $J^{PC} = 1^{+-}, 1^{-+}$

Combined with  $0^{-+}$  ( $\pi, K$ )  
yields

$$J^{PC} = 1^{++} \text{ and } 1^{--}$$

Combined with  $1^{--}$  ( $\rho, \omega, \Phi$ )  
yields

$$J^{PC} = 0^{+-}, 0^{-+}, 1^{+-}, 1^{-+}, 2^{+-}, \text{ and } 2^{-+}$$

**Exotics!**

# Energy Choice

- We want to do more than just measure one state -- we would like to map out nonets of exotics
- Design experiment to reach masses near  $3.0 \text{ GeV}/c^2$
- High mass is quickly suppressed by exponentially falling  $t$  distribution

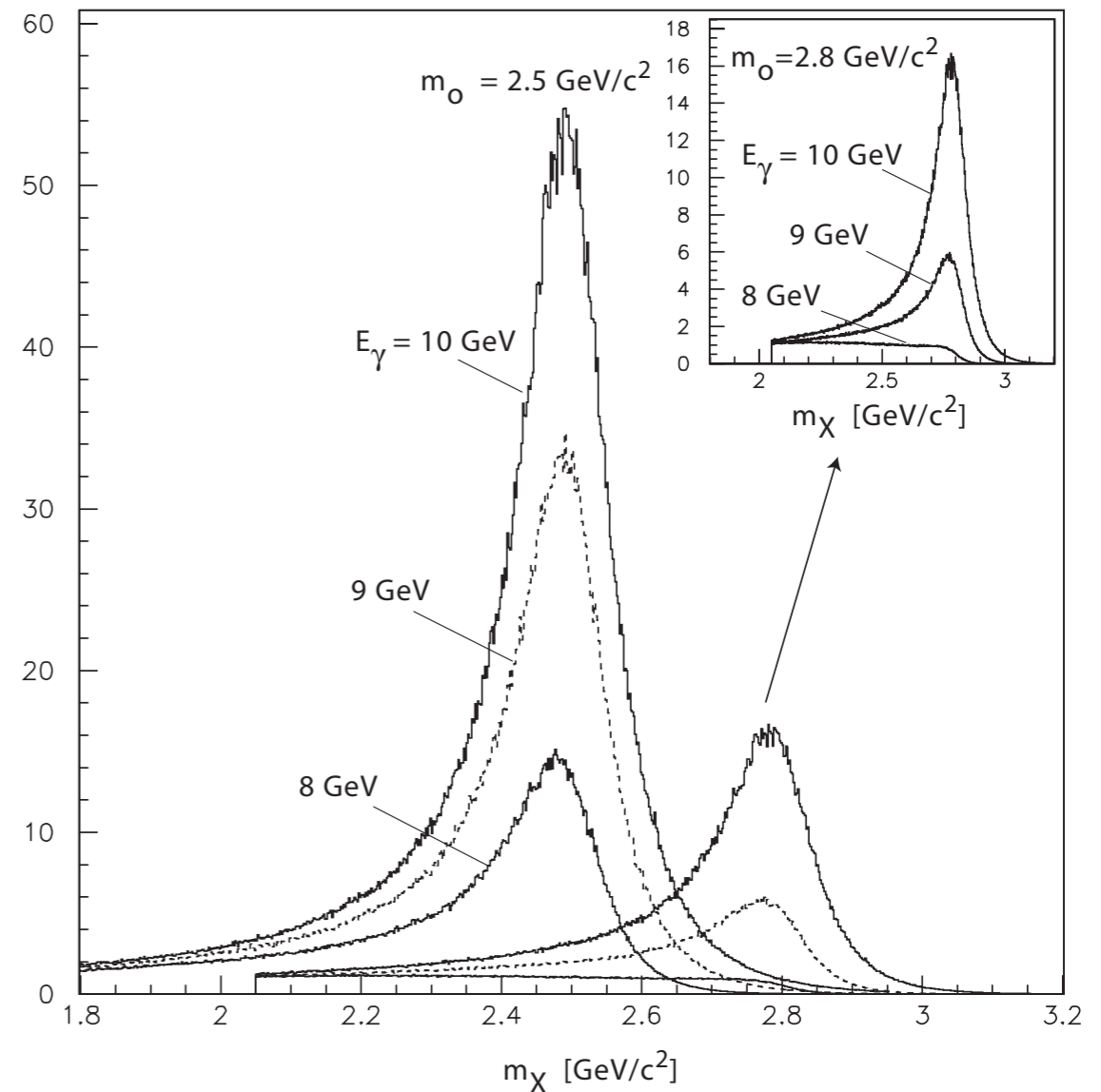
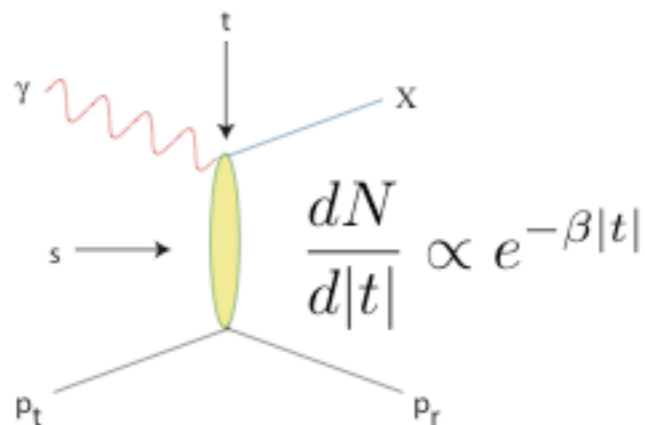

9 GeV photons provide sufficient mass reach

# Linear Polarization

- Coherent bremsstrahlung technique produces 9 GeV linearly polarized photons from thin diamond wafer
- Linear polarization encodes the spin/parity of exchanged particle in the azimuthal angle of decay products
- Critical extra handle in spin/parity analysis of final state
- Can be used to increase sensitivity to exotics

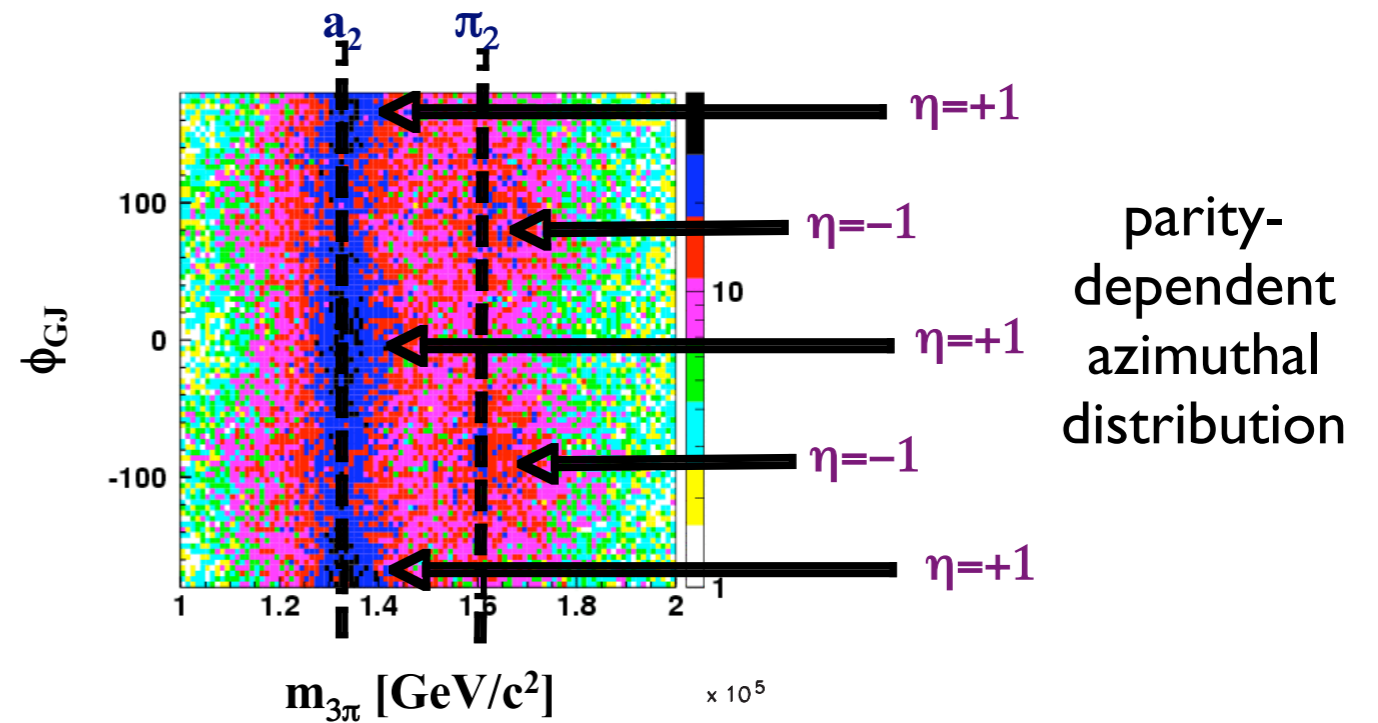

Simulated  
GlueX Analysis  
 $\gamma p \rightarrow 3\pi n$

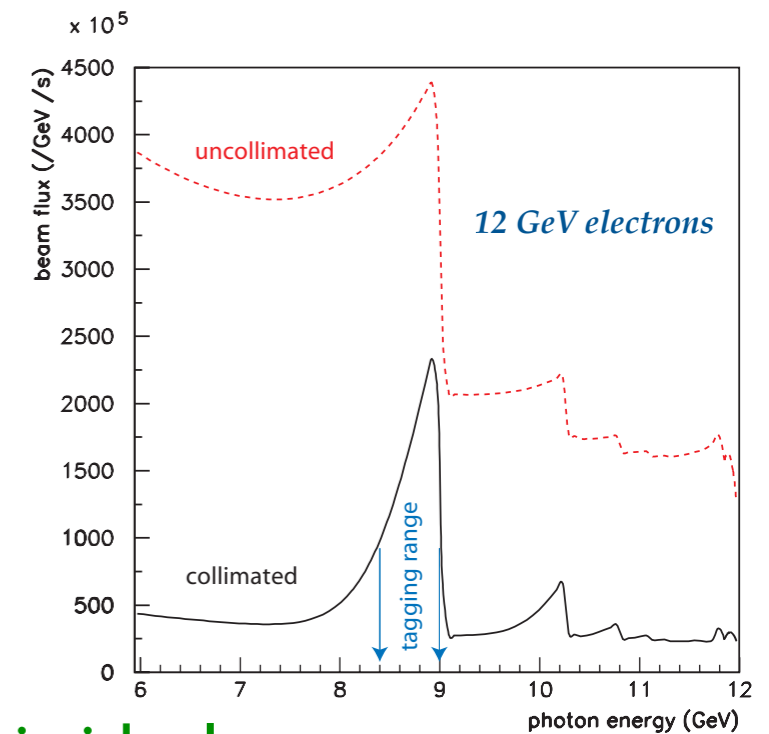

A linearly polarized 9 GeV photon beam is ideal

# Predicted Decay Modes

- For the lowest mass  $1^{-+}$  the flux-tube model predicts decay into  $L=1, L=0$  meson
- Leads to experimentally challenging final states
- *Need high acceptance for both charged and neutral particles*
- isospin symmetry is an important cross-check in the analysis
- Amplitude analysis is required to extract the physics

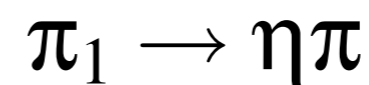
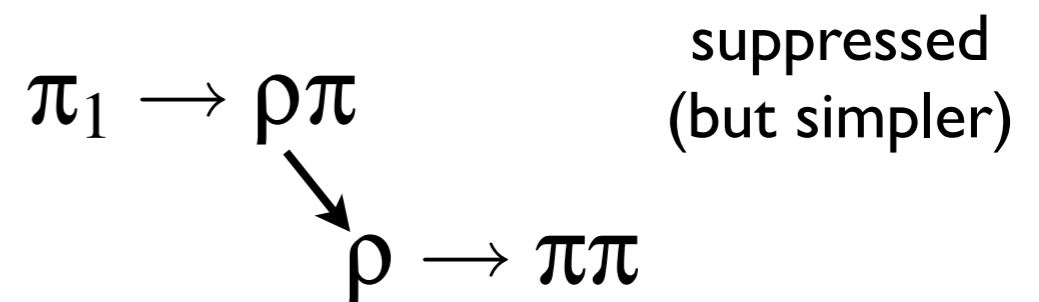
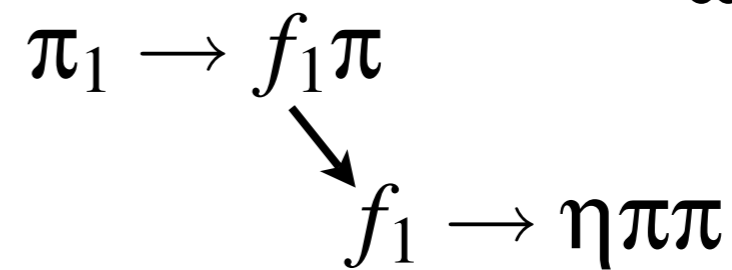
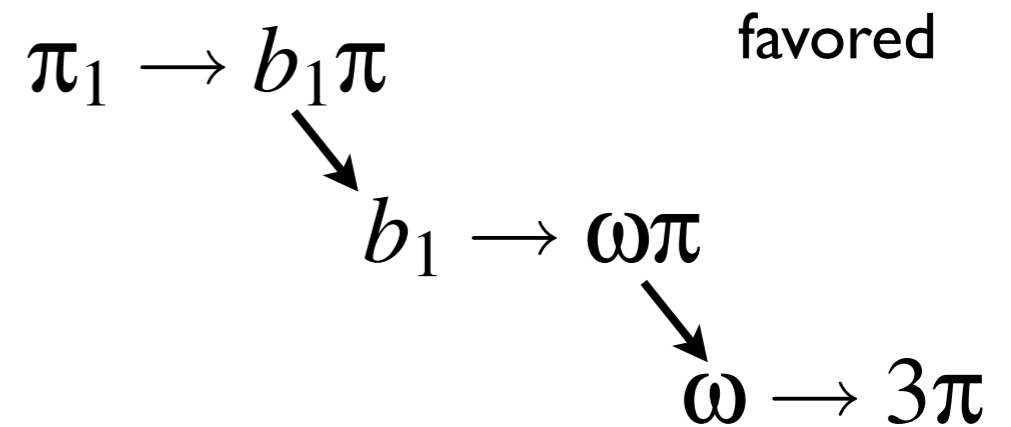

# Overview

- Utilize 9 GeV linearly polarized photons (from 12 GeV electrons) to produce hybrid mesons
- State of the art detector optimized for doing multi-channel amplitude analysis
- Statistics will surpass present data samples by orders of magnitude

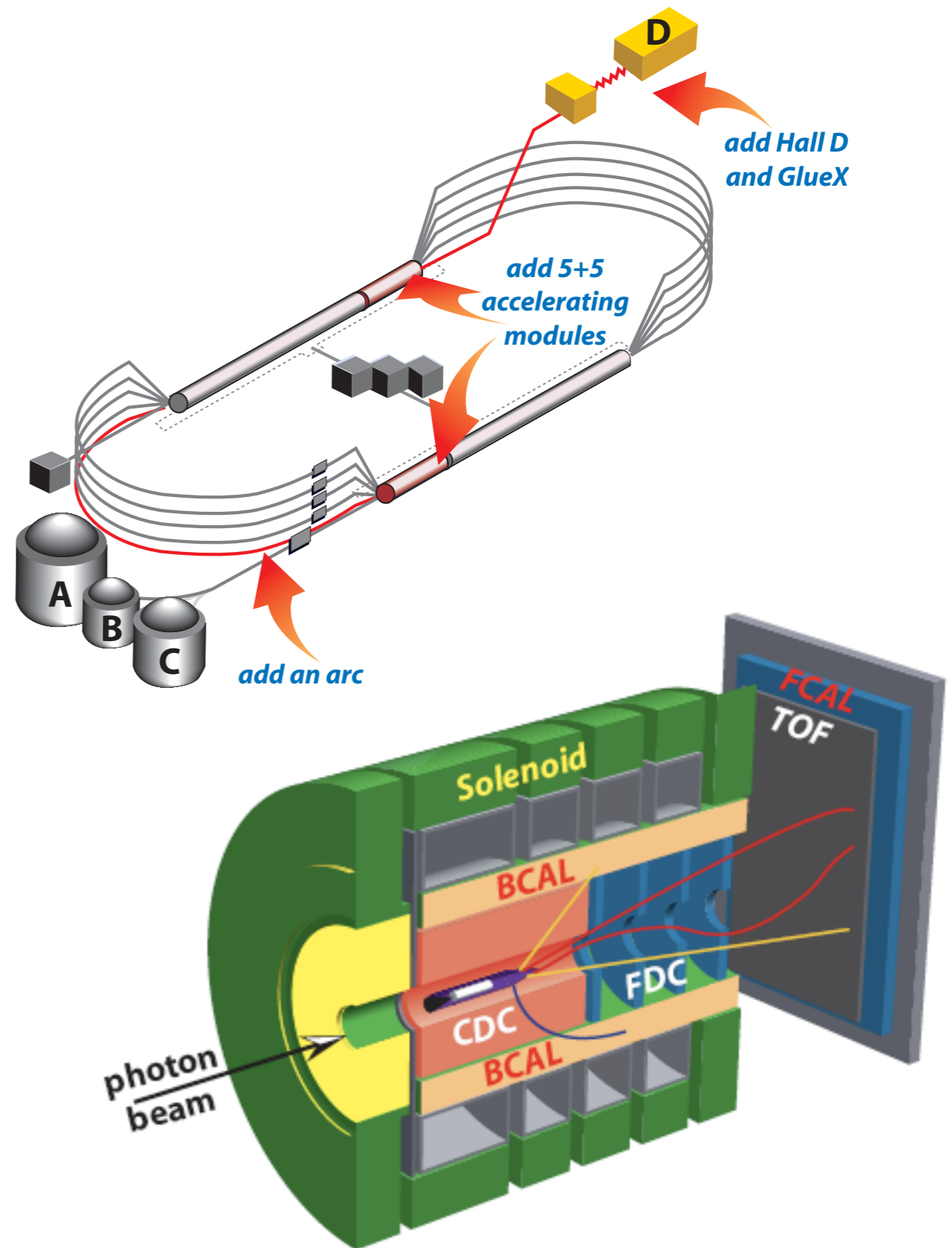

# The Hall D Complex

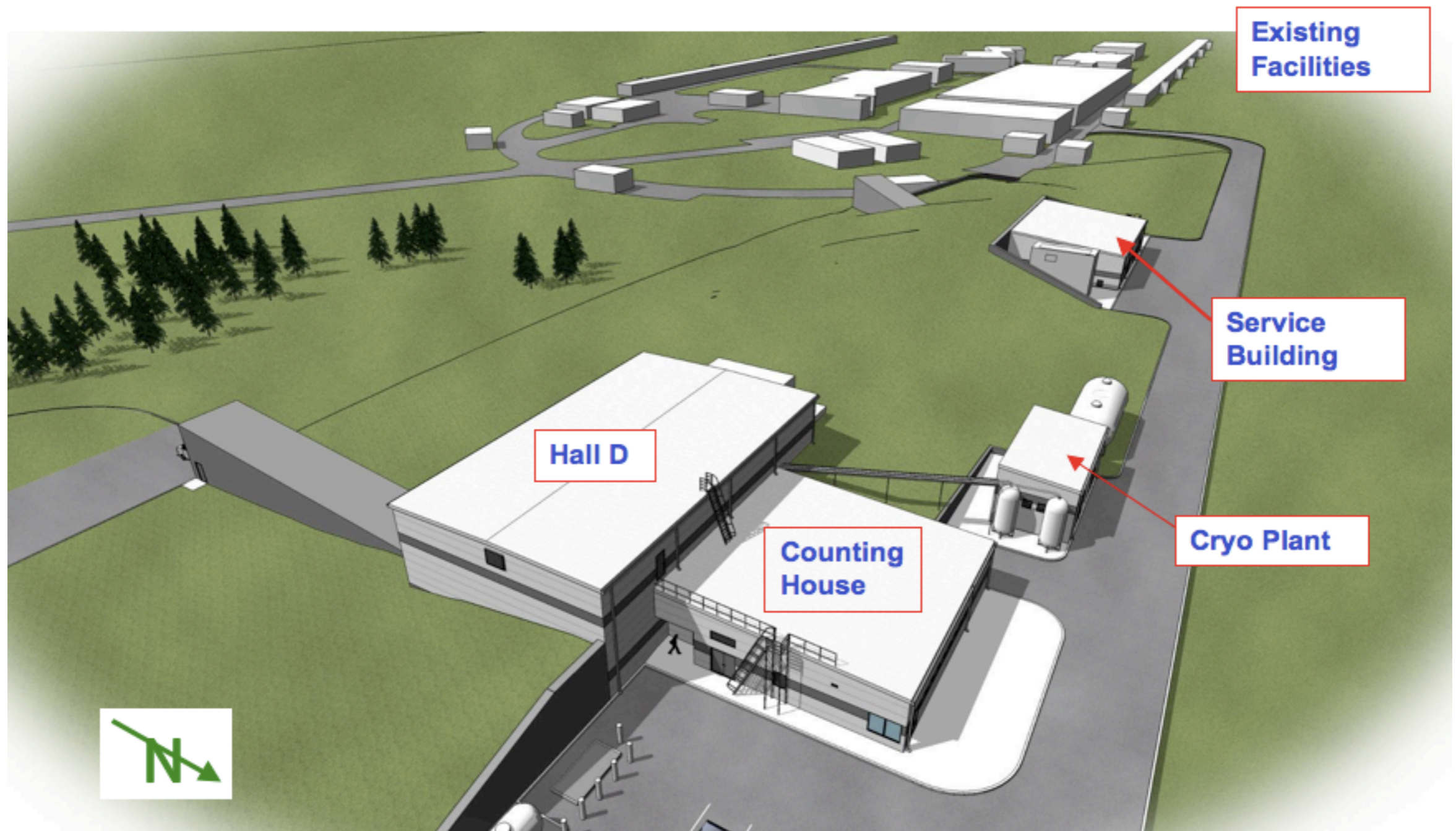

# GlueX in Hall D

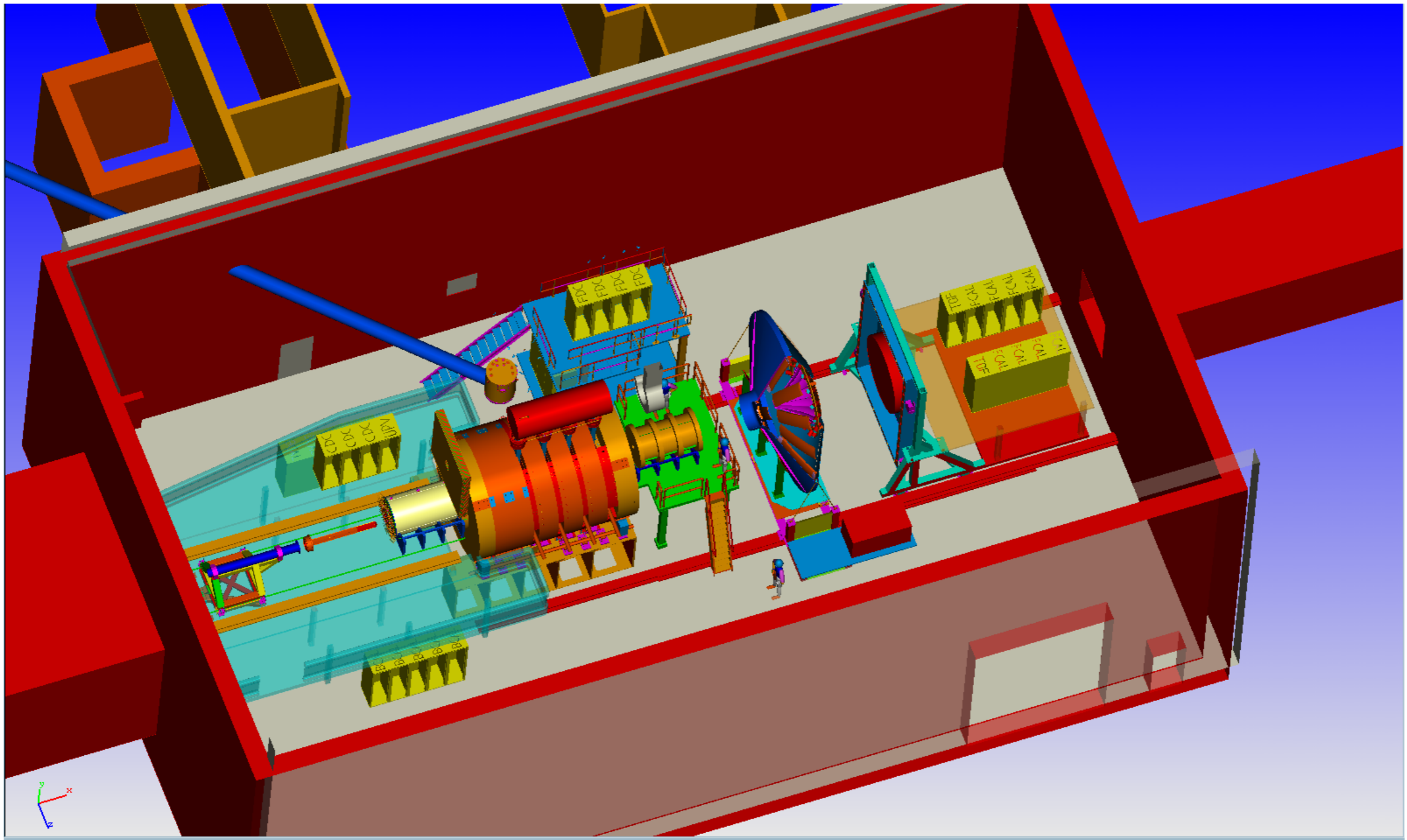

DEPARTMENT OF PHYSICS

INDIANA UNIVERSITY  
College of Arts and Sciences  
Bloomington

# Tracking

**Goals**

coverage:  $1^\circ \leq \theta \leq 140^\circ$   
 resolution:  $\sigma/p = 1-3\%$

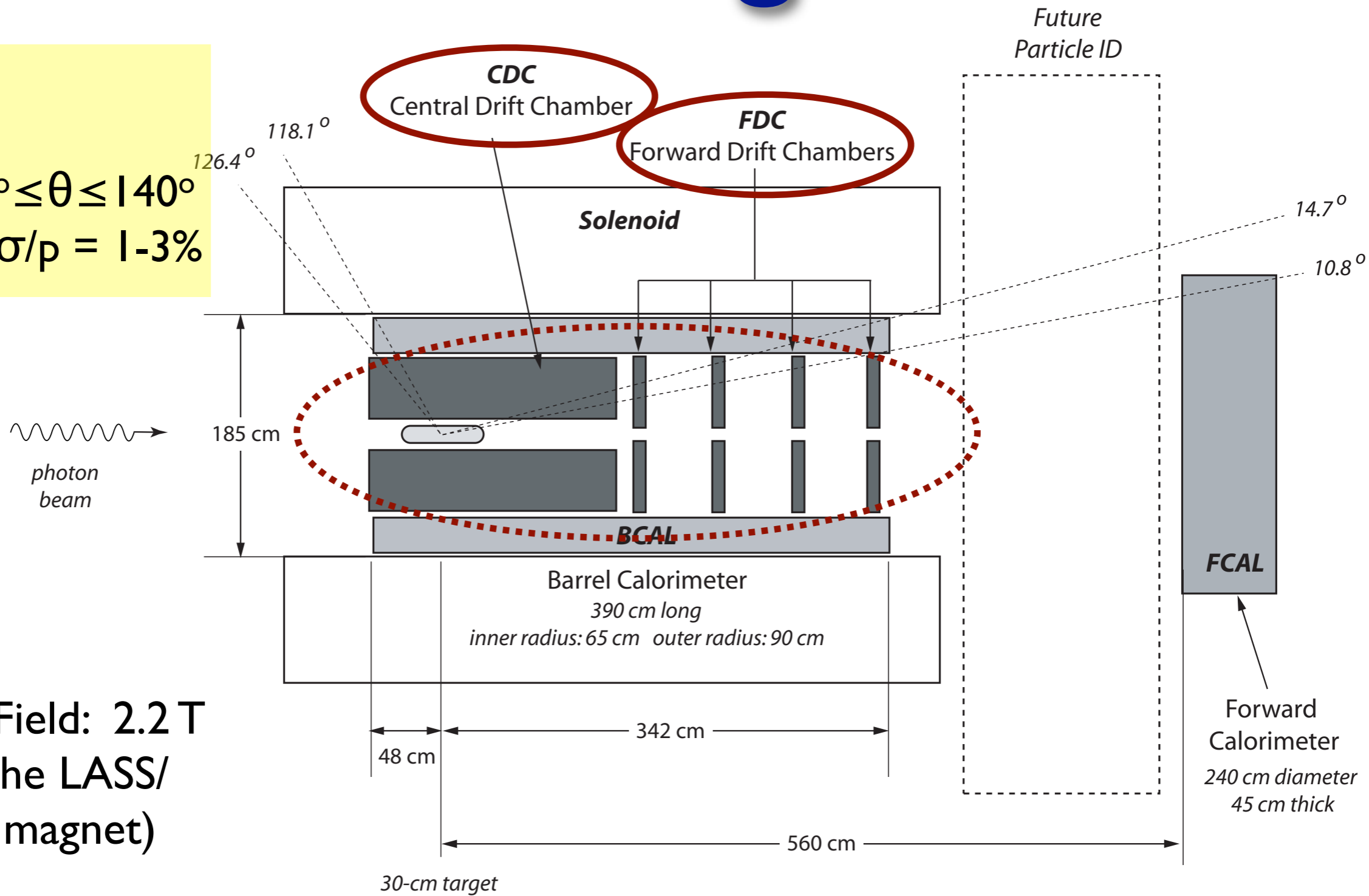

Solenoid Field: 2.2 T  
 (reuse the LASS/  
 MEGA magnet)

# Central Drift Chamber CDC

- Straw-tube central drift chamber
  - 3098, 1.6 cm dia. Al-kapton straws
- 24 layers total
  - 8 stereo layers with  $\pm 105$  mrad stereo angle
- Target resolution:
  - $150 \mu\text{m } r/\Phi$
  - 2 mm z

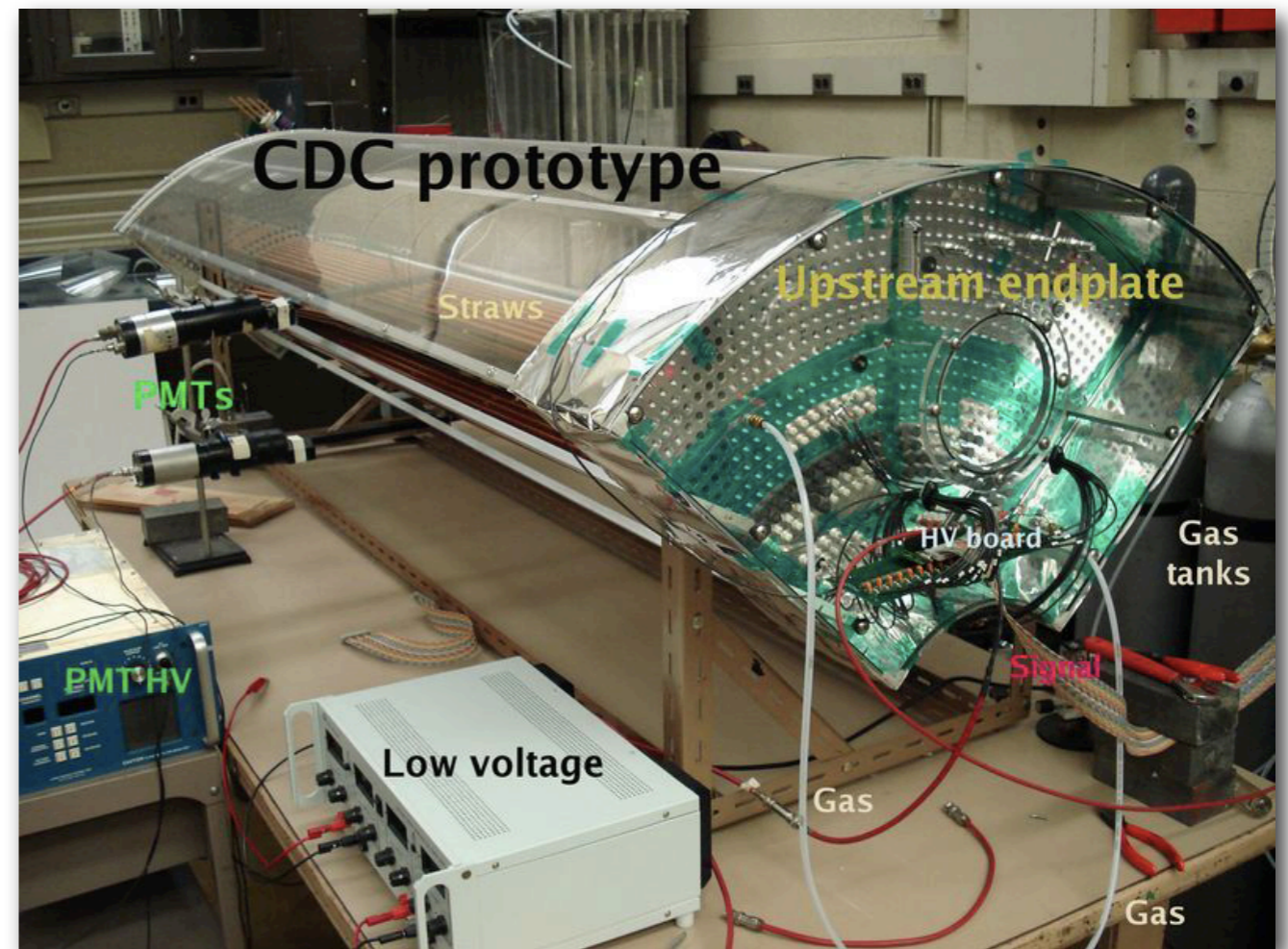

*Full scale, 1/4 CDC prototype*

# Forward Drift Chamber

## FDC

- 4 packages, each 6 layers
- Every layer: u/v cathode strip readout with anode wire plane between
- Wire plane orientations rotate by  $60^\circ$  progressively within package
- Target resolution:  $200\ \mu\text{m}$
- Channel count: 10368 (cathode) + 2304 (anode)

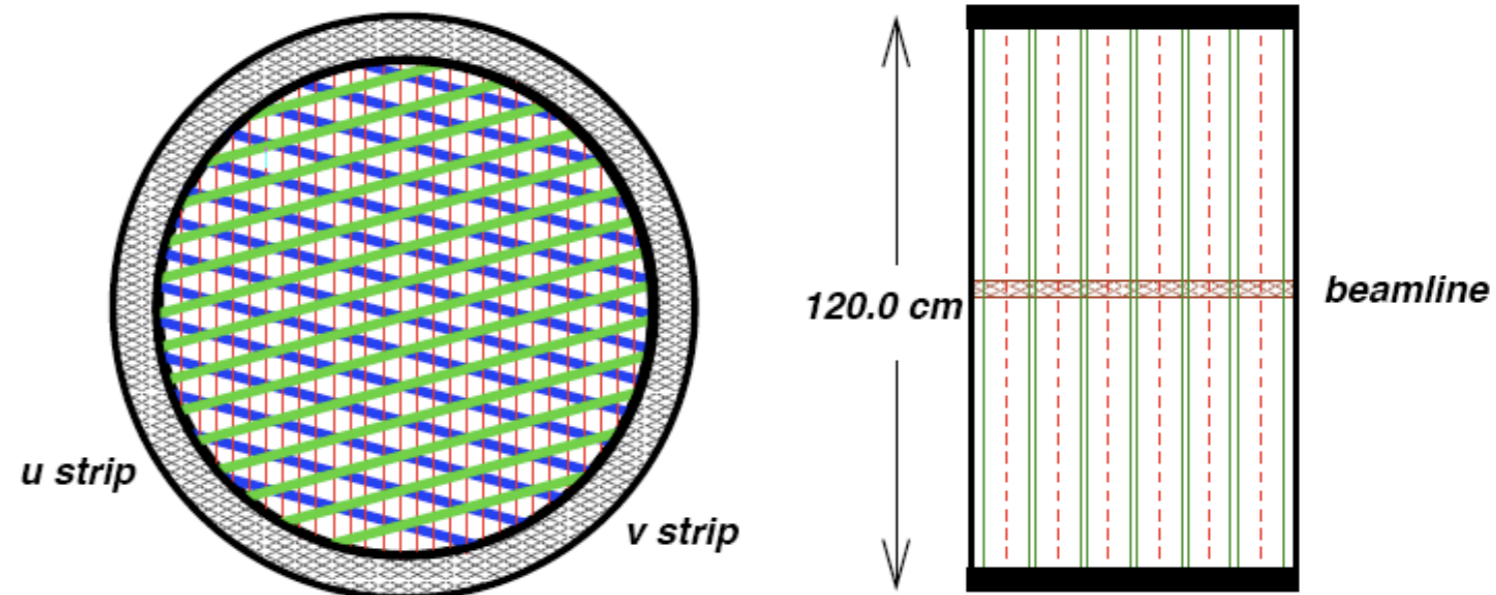
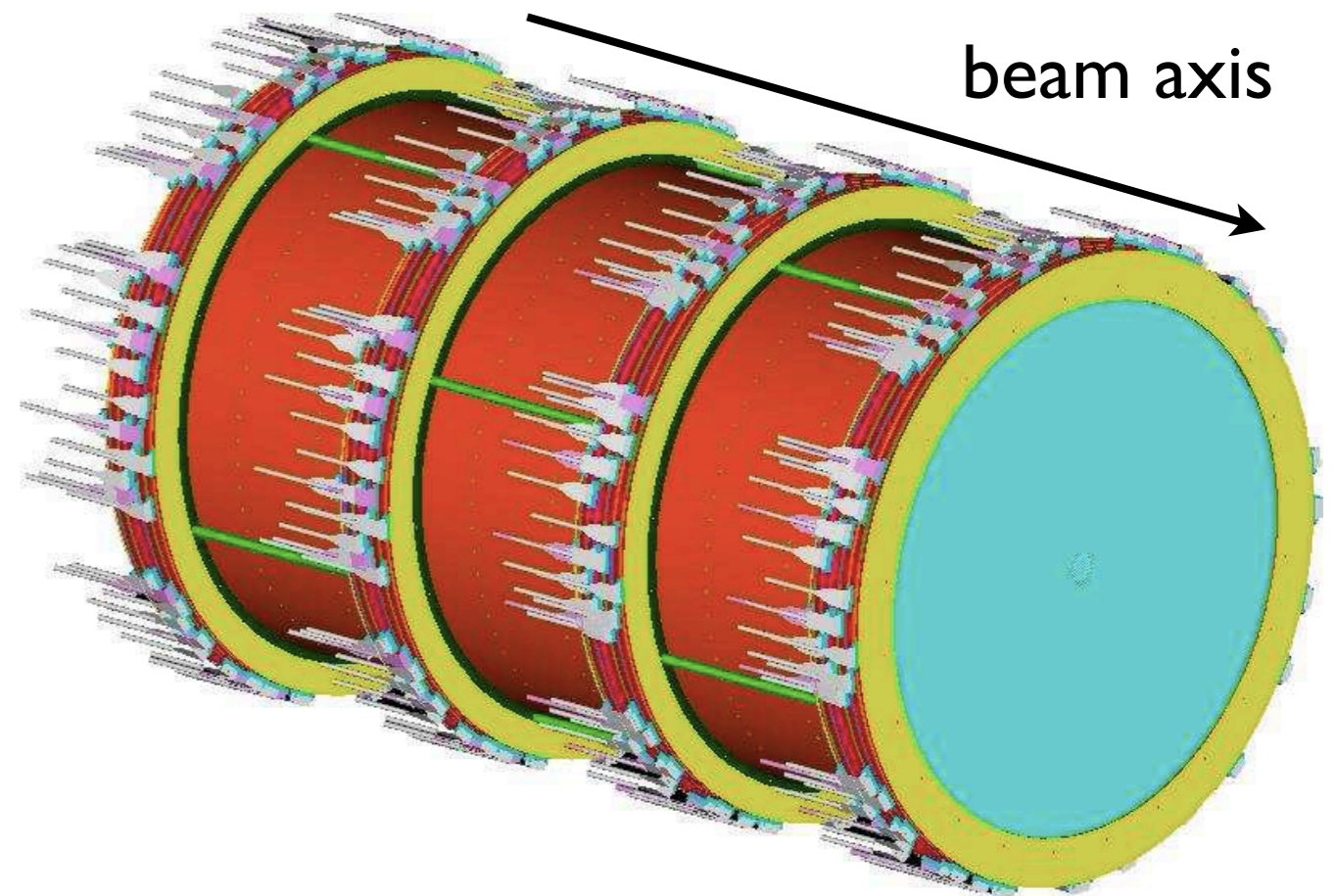

# Calorimetry

## Goals

coverage:  $2^\circ \leq \theta \leq 120^\circ$

average approximate resolution:

$$\sigma/E = 6\%/\sqrt{E} + 2\%$$

low energy threshold:

forward: 80 MeV  
barrel: 30 MeV

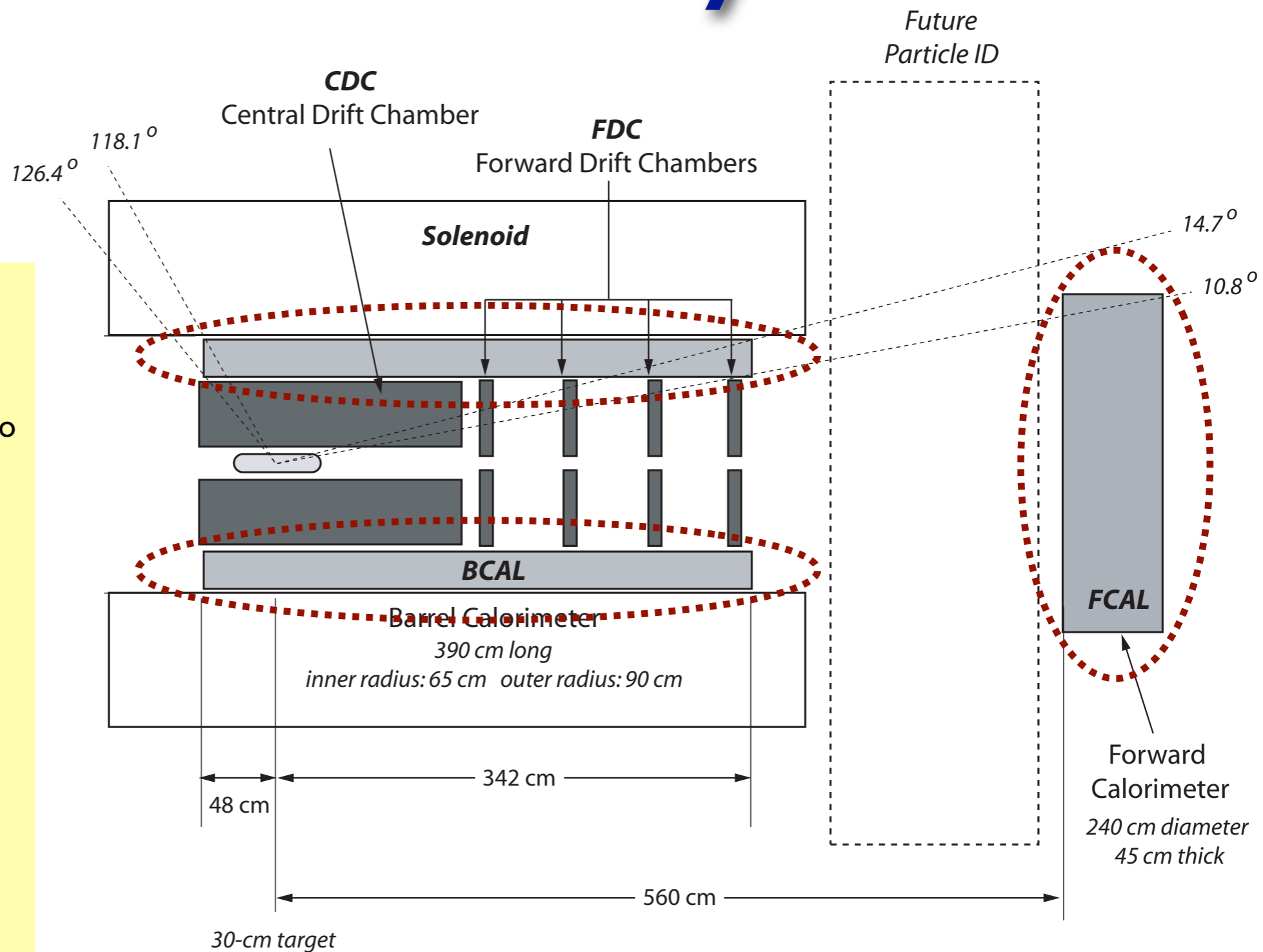

# Barrel Calorimeter

## BCAL

- Lead/scintillating fiber matrix
- Based off of the KLOE calorimeter design
- Fast green fibers (BCF-20) coupled to green-sensitive SiPMs enhance performance
- Anticipated resolution
  - $\sigma/E = 5\%/\sqrt{E} + 1\%$

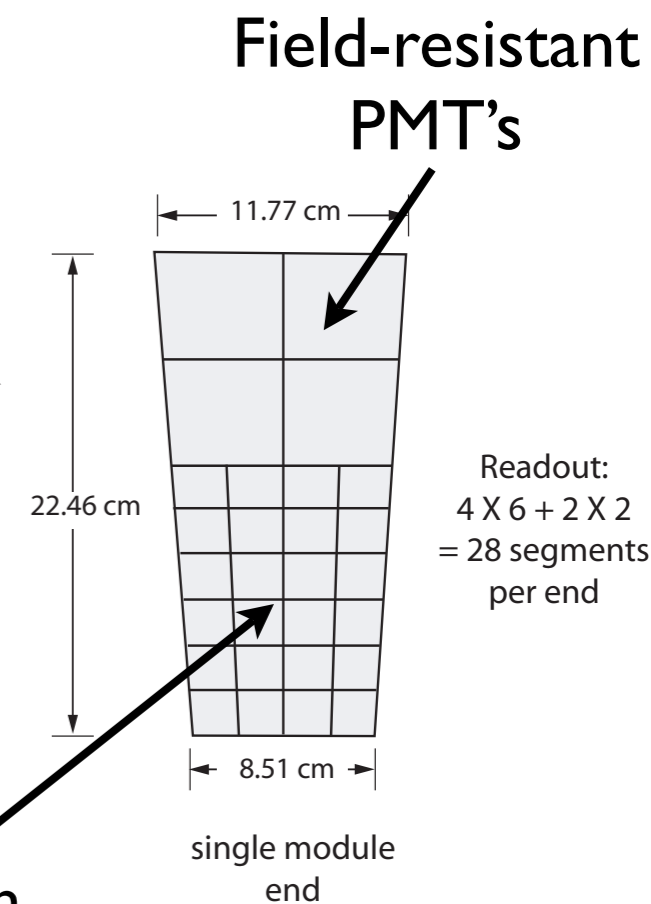
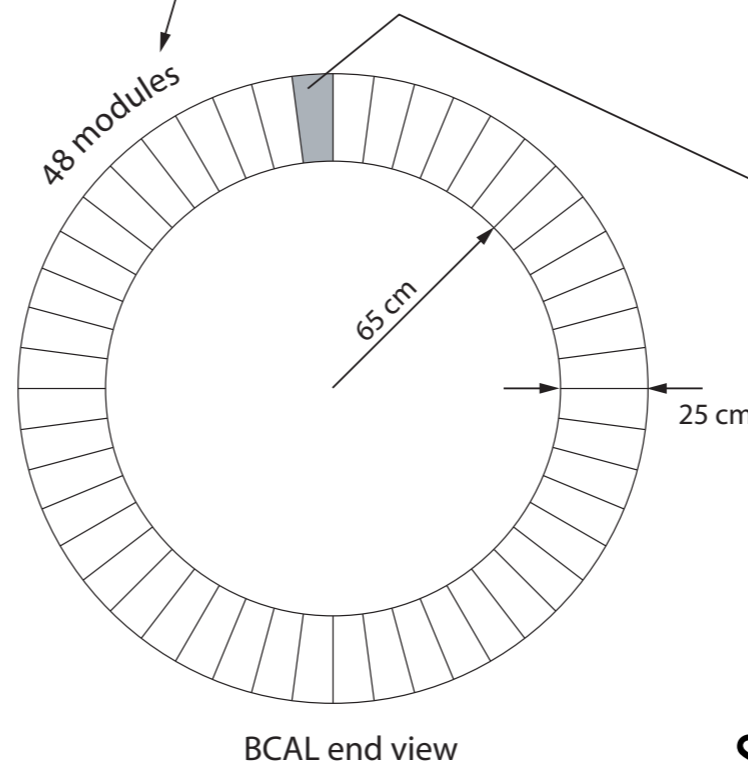
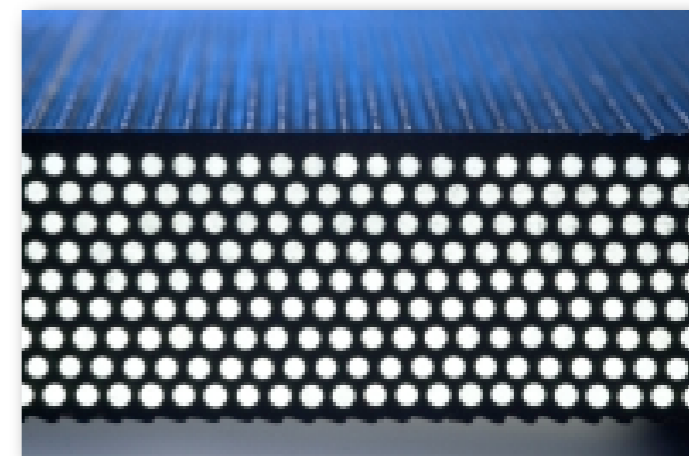
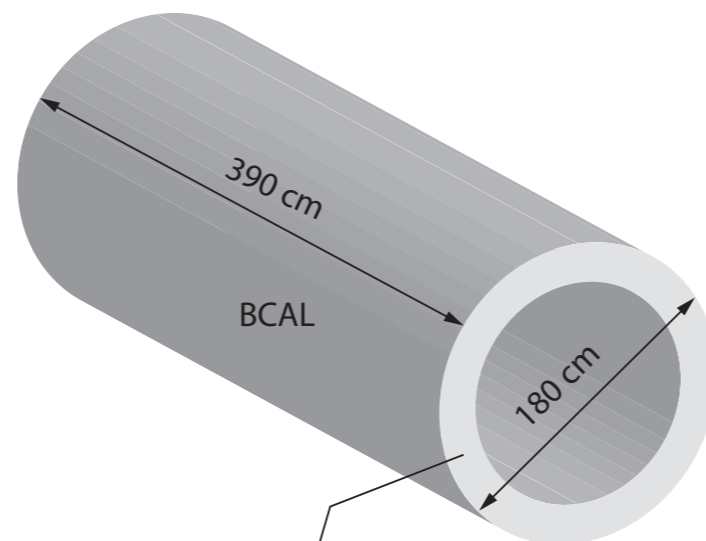

Readout:  
4 X 6 + 2 X 2  
= 28 segments  
per end

# SiPM Readout for BCAL

- Inner layers of BCAL will be read out with large area (1.2 cm x 1.2 cm) silicon photomultipliers, which tolerate high field.
- Single PE dark rate < 50 MHz
- Gain  $\sim 10^6$  and detection efficiency similar to that of conventional PMTs
- Sensitivity is well matched to output of BCF-20 “green” fibers

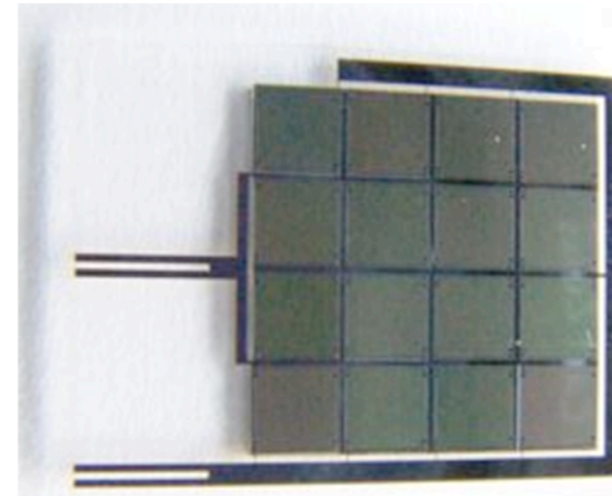

large area device

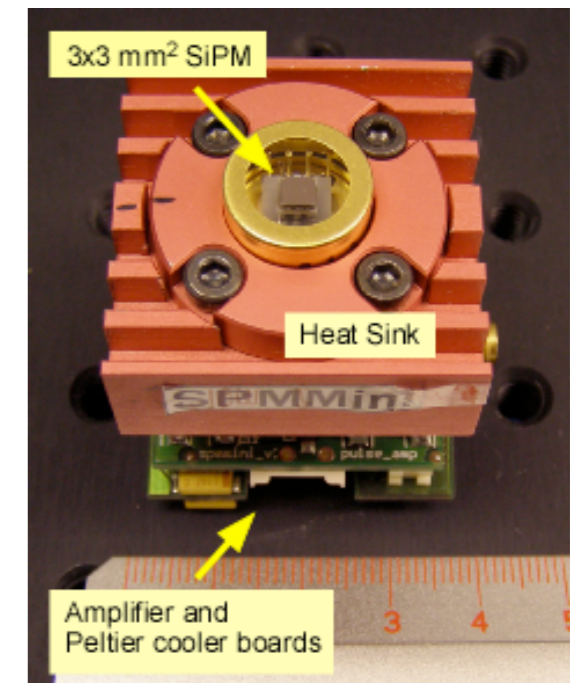

Charge spectrum shows clear “photoelectron” peaks

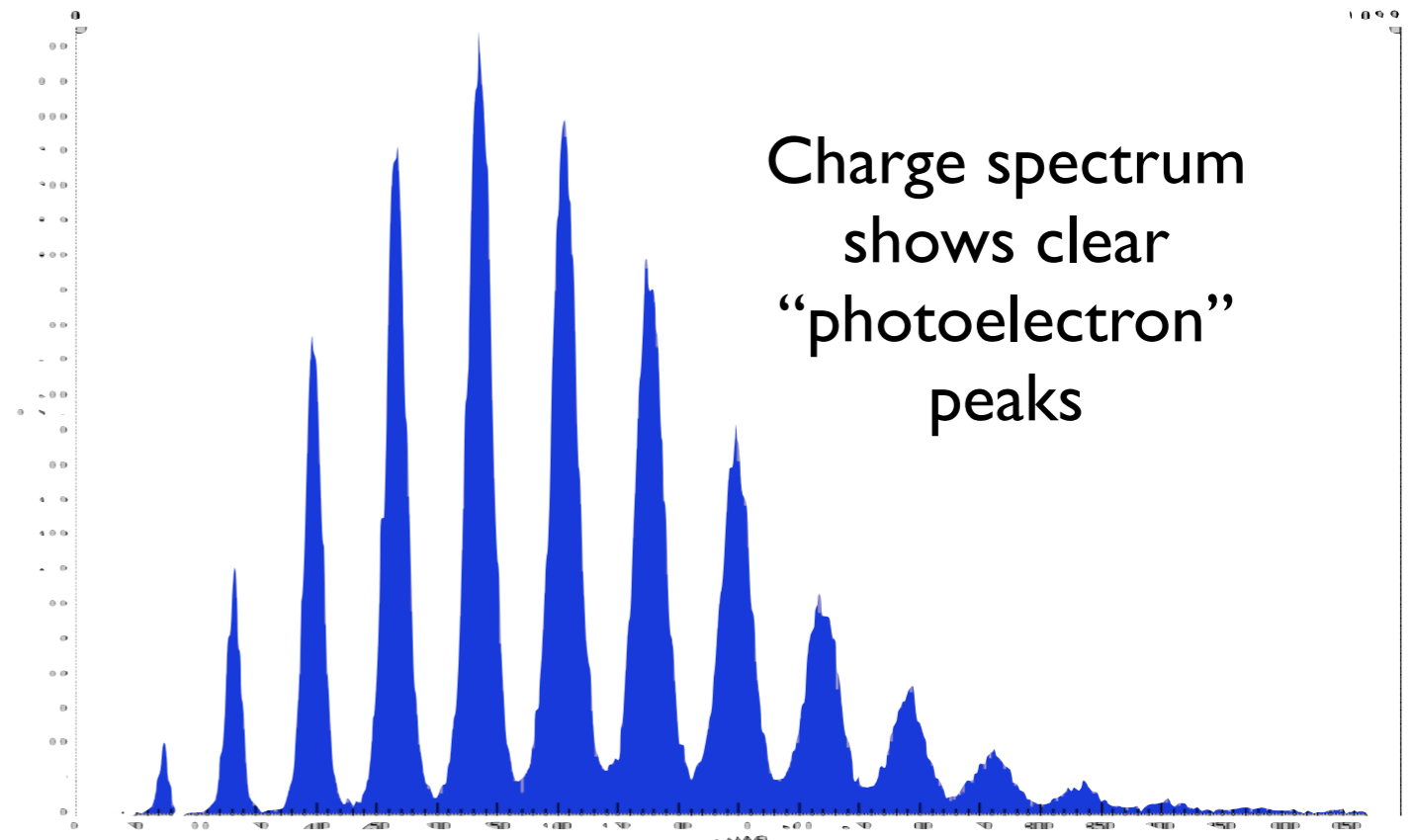

# Forward Calorimeter FCAL

- Lead glass calorimeter
  - 2800 blocks, each 45 cm x 4 cm x 4 cm
- 1" PMT readout
- lead glass and general design from E852 (BNL) and RadPhi (JLab) experiments
- Anticipated resolution
  - $\sigma/E = 6\%/\sqrt{E} + 2\%$

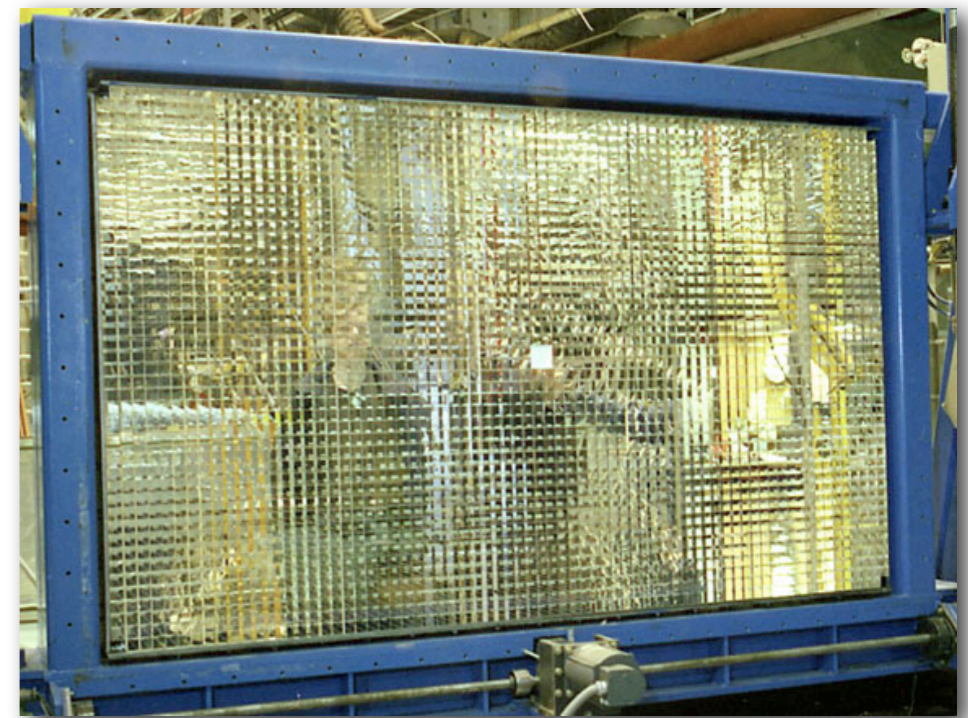

*The E852  
Calorimeter*

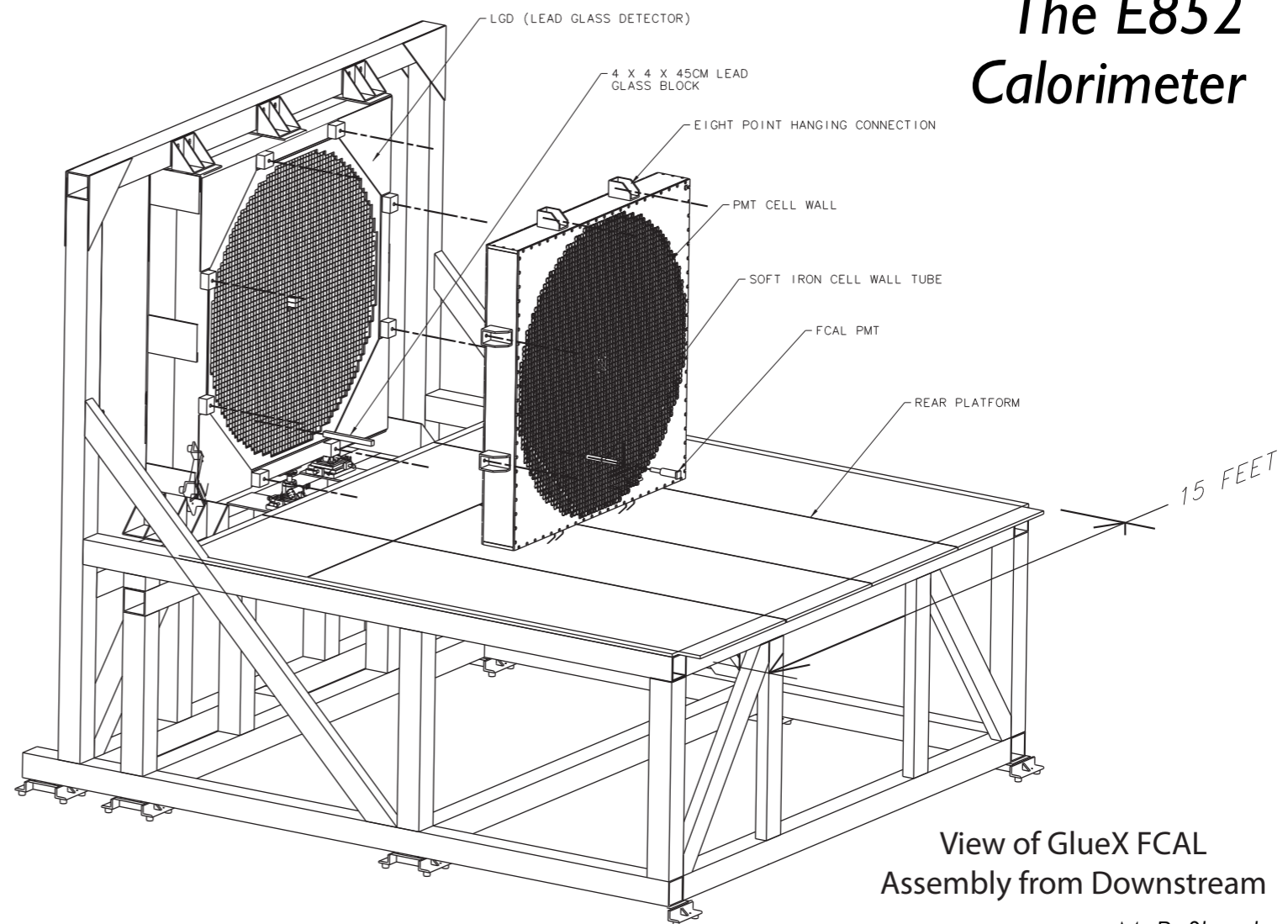

View of GlueX FCAL  
Assembly from Downstream

M. R. Shepherd  
PHP 2008, Jefferson Lab  
March 6, 2008

# Calorimetry Coverage

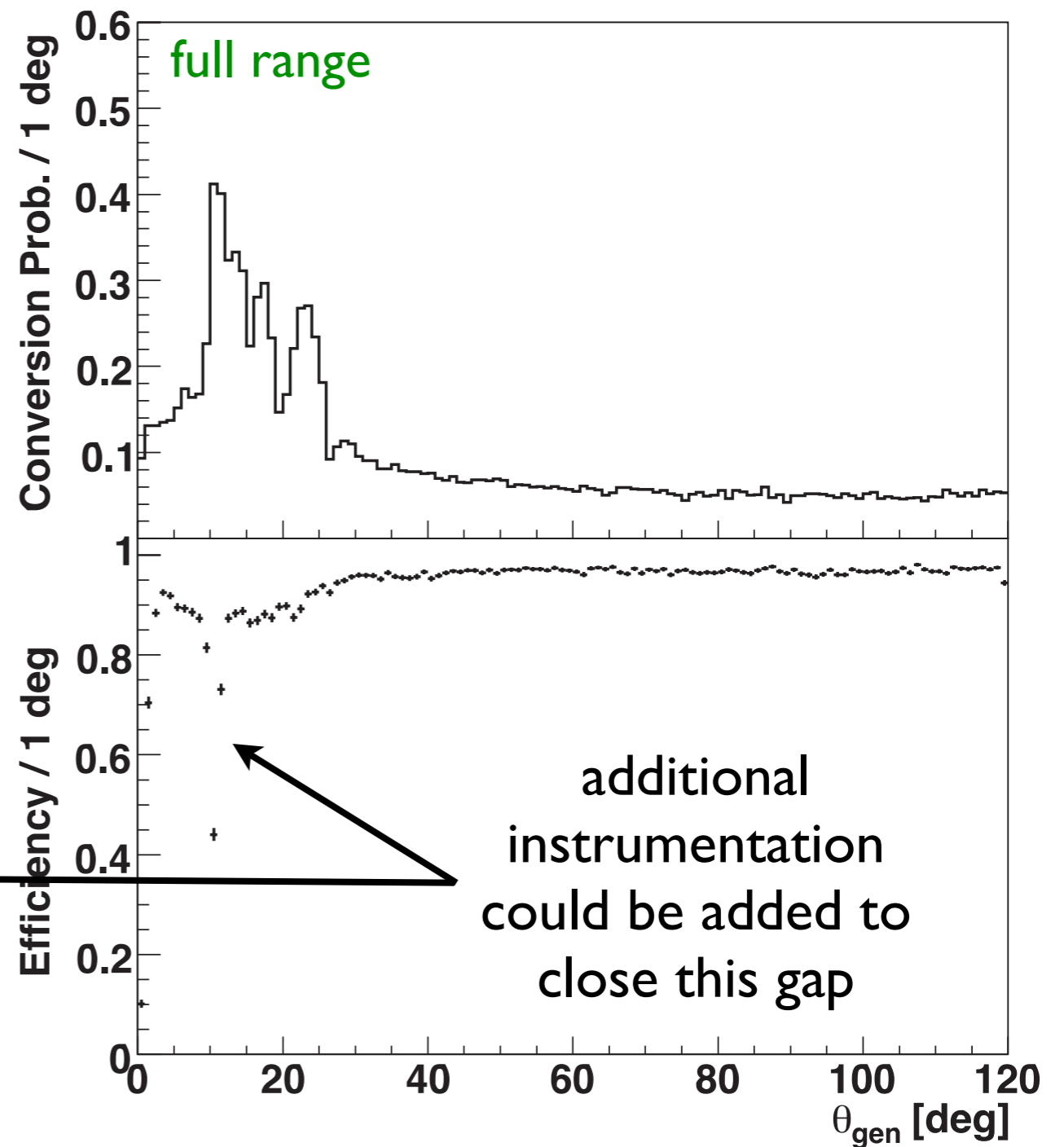
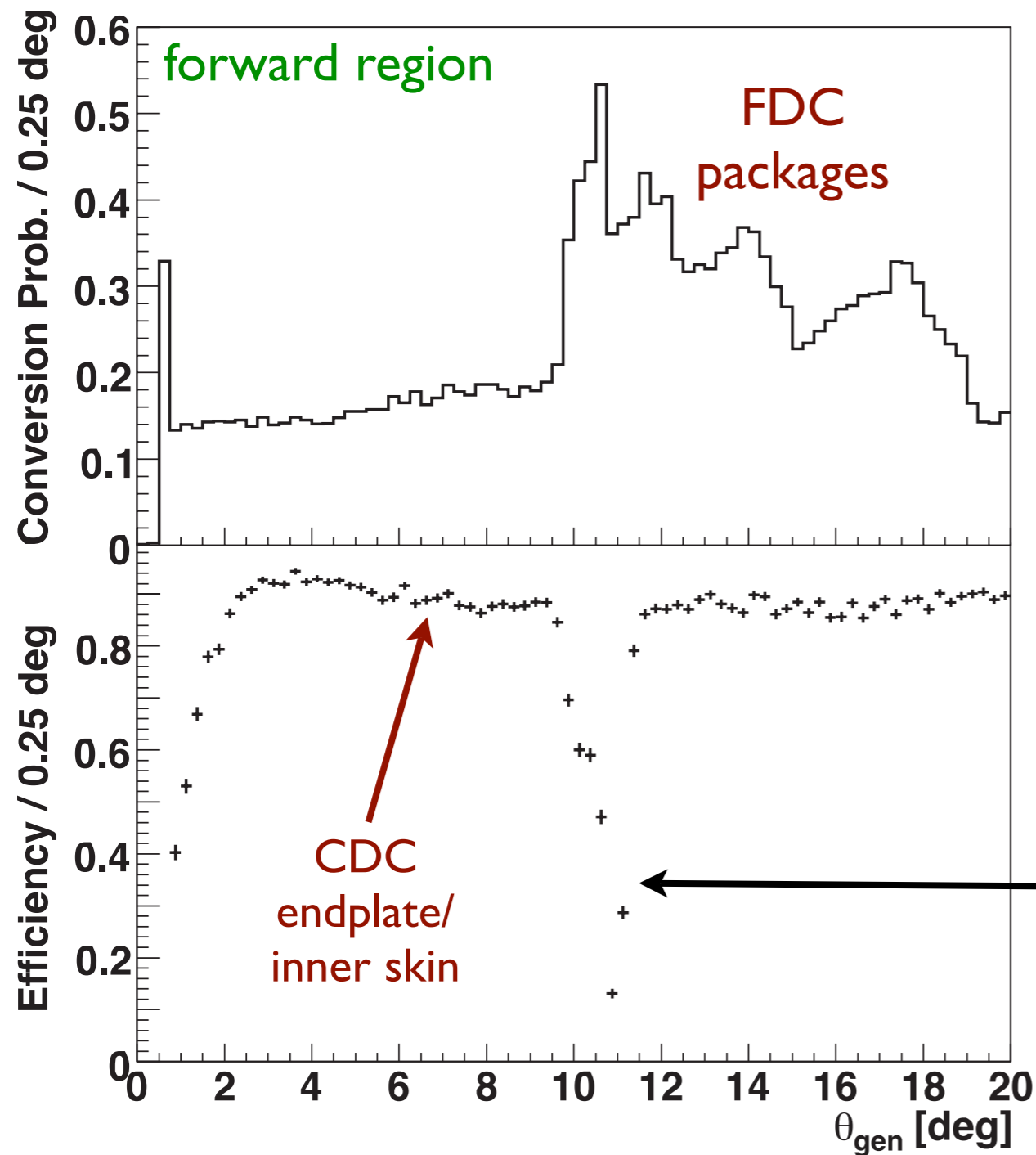

# Particle ID/Timing

Start  
Counter  
segmented  
scintillator  
around  
target  
 $\sigma_t \sim 250$  ps

We need to identify  
beam bunch to select  
the correct tagger hit  
and determine the  
event time.

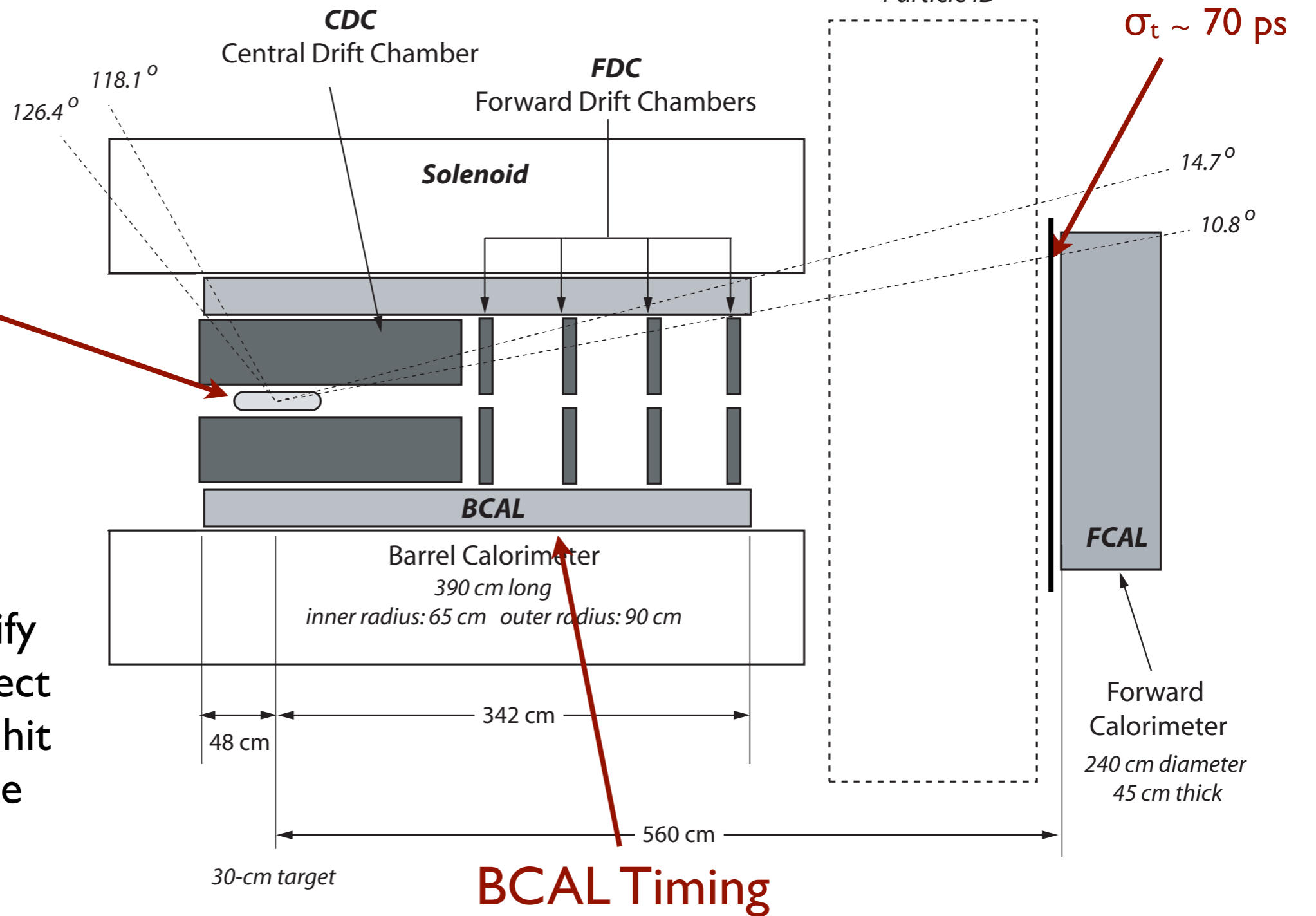

BCAL Timing

# Particle ID

- Baseline PID includes:
  - $dE/dx$  in chamber
  - time of flight to BCAL
  - $dE/dx$  in BCAL
  - time of flight to FCAL (from forward TOF detector)
- Sufficient for recoil proton ID, eliminating K backgrounds
- Baseline PID enables core program of non-strange spectroscopy
- *Physics reach could be strongly enhanced with kaon ID – excellent opportunity for upgrade!*

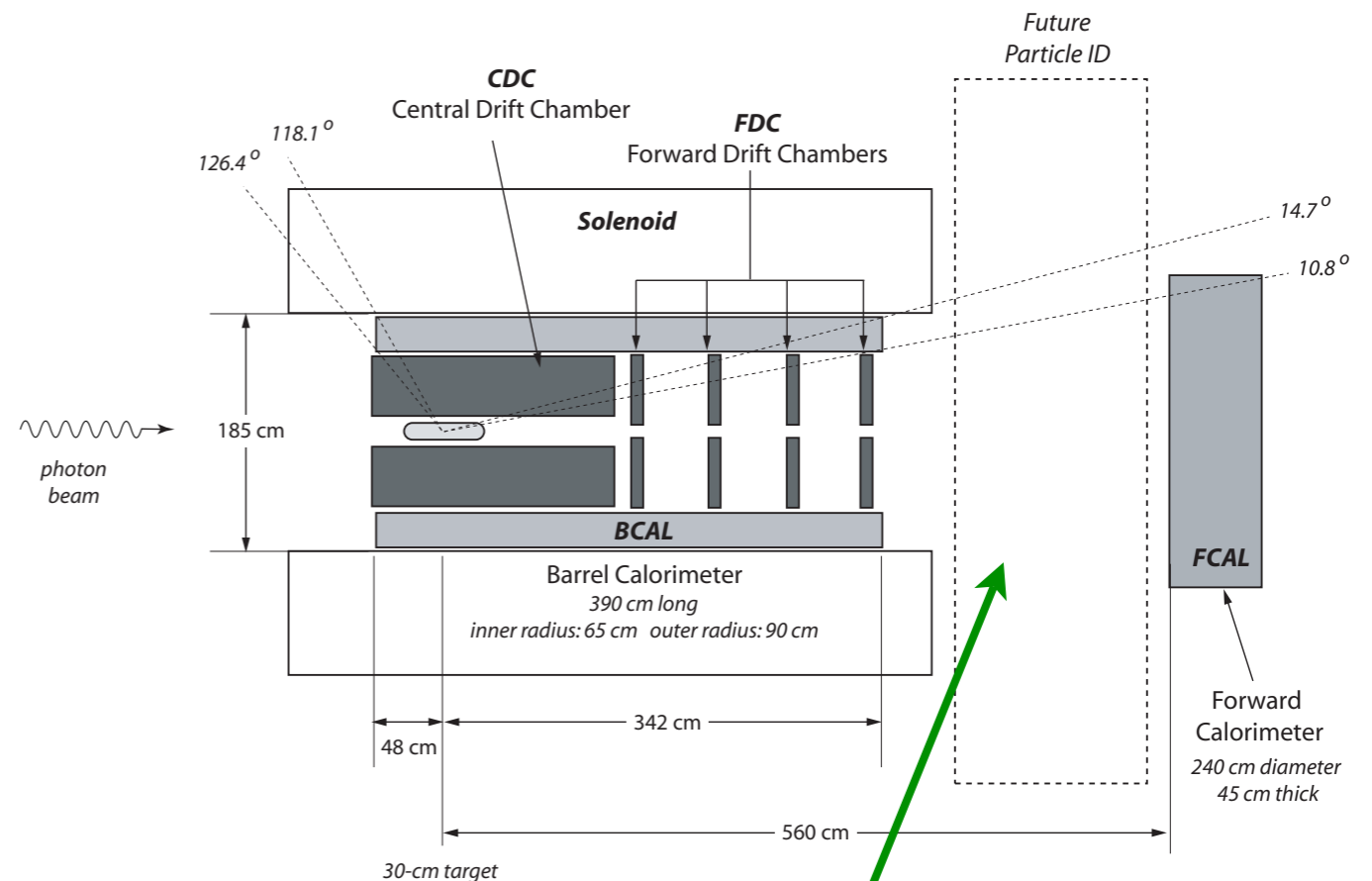

*large volume in the forward direction is available for future PID upgrade*

# Electronics/Trigger

- At final design photon flux of  $10^8$   $\gamma$ /s anticipate hadronic event rate of 200 kHz
  - LI: 200 kHz
  - 15 kHz (2 GB/s) to disk through L3 farm
- Entire detector utilizes “deadtimeless” pipelined electronics design built from common flash ADCs and multi-hit TDCs
- Trigger on total energy in calorimeters and track count from TOF, START, and BCAL

250 MHz, 10-bit  
FADC

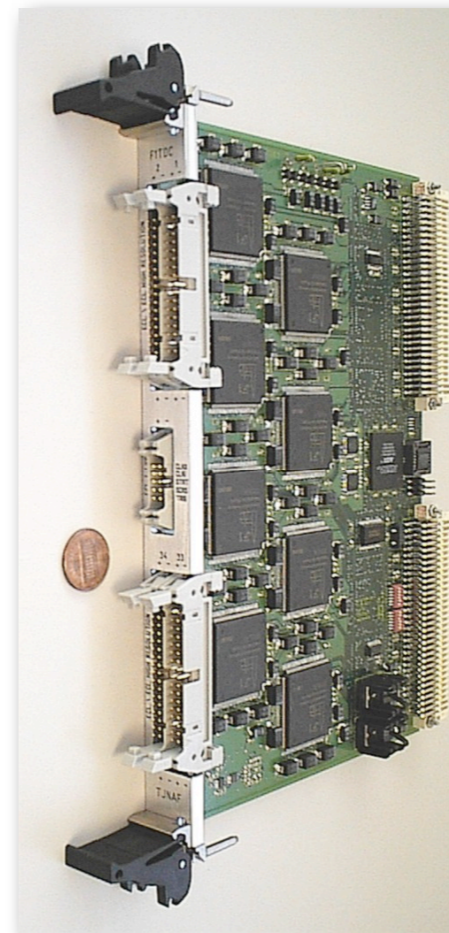

60 ps LSB, multi-hit  
FI TDC

# Summary

- Baseline design inspired and driven by core program of non-strange hybrid spectroscopy
  - high-intensity, 9 GeV linearly-polarized photon beam
  - large acceptance detector for both charged and neutral particles
  - *result: a multi-purpose GlueX detector*
- There are many opportunities to contribute to the execution of the baseline design as well as future upgrades
- We look forward to discussing how we develop the detector capability to capitalize on the broad range of accessible physics topics.

